

# TriMark<sup>®</sup>

DOOR SYSTEMS

*Access to Excellence*



TRIMARK'S LINE OF  
PRIMA HANDLES AND  
LOCKING DEVICES

 **PRIMA<sup>®</sup>**  
INDUSTRIES S.R.L.

TriMark Corporation is pleased to announce that it has an exclusive distribution agreement with Prima Industries (Correggio, Italy) to sell and distribute their portfolio of Handles and Locking Devices to the Mass Transportation market in North America including the USA, Canada and Mexico. This catalog contains a cross section of standard products that are available from TriMark.



### **About TriMark Corporation**

TriMark Corporation is an employee-owned company and is a recognized leader in the design and manufacture of quality hardware products for the recreational vehicle, agricultural, truck, construction, and enclosure markets. The TriMark corporate headquarters is located in New Hampton, Iowa, USA. TriMark serves the China market through TriMark Xuzhou and the European market through its subsidiary, TriMark Europe Ltd, based at Bardon Hill, near Coalville, Leicester. TriMark has been a valued partner supplier to Caterpillar for more than 30 years, in addition to other global customers, including John Deere, Volvo, Paccar, AGCO, Case New Holland, and Winnebago, who provide world class vehicles and equipment. For more information, visit [www.trimarkcorp.com](http://www.trimarkcorp.com).



### **About Prima Industries**

Prima Industries is one of the leading companies in the field of components for mass transportation vehicles with a market presence in 63 countries. Prima products include latches, locking devices, air diffusion systems, light diffusion systems, city bus tubing supports and stop request/call buttons, interior bus accessories, luggage rack systems and luggage door systems. Prima clients are the big vehicle producers such as Iveco, Daimler, Scania, Deutsche Bahn, Komatsu, Volvo, Caterpillar, New Holland, Lamborghini Auto and Van Hool. For more information, visit <http://www.primaindustries.it/>.

# Table of Contents

## Door Handles

P119 Locking Door Handle .....	4
P141 Locking Door Handle .....	4
P397 Locking Door Handle .....	5
P183 Flush Compartment Handle .....	5
P179 Luggage Compartment Handle .....	6
P332 Locking Door Handle .....	6

## Driver's Door Handles

P61 Driver's Door Handle .....	7
--------------------------------	---

## Passenger's Door Handles

P203 Lav Door Handle.....	7
P230 Electronic Door Handle.....	8
P247 Emergency Door Handle.....	8

## Interior Handles

P117 Locking Pin.....	9
P246bis Door Handle.....	9

## Key Locks

P474 J.O.K. Lock/Key Set.....	10
-------------------------------	----

## Locking Devices

P70 Forked Lock Latch .....	10
P62 Forked Lock with Logic .....	11
P130 Control Pin with Slot .....	11
P70bis Control Pin .....	12
P271 Clasp Lock.....	12

## Lock Accessories

P238 Locking Pin .....	13
P301 Pin Strike .....	13
P144 Lock Cover .....	14

## Window Locks

P59 Sliding Window Knob.....	14
P76 Sliding Window Lock.....	15

## Accessories

.....	16
-------	----

## 120-1000 ClassicDOOR Hinge System

.....	17
-------	----

## Full Systems Solutions

.....	18
-------	----



# P119 Locking Door Handle

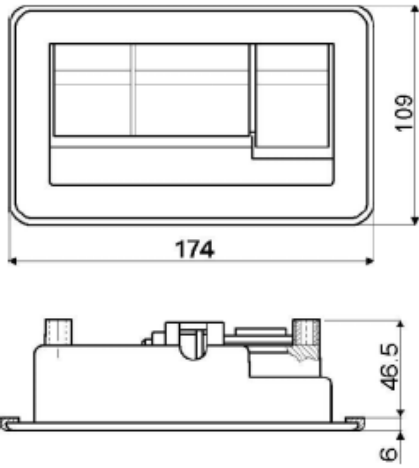

The P119 Locking Handle is a standard locking door handle for use with entrance and compartment doors. Available in three different operational models: Manual, pneumatic, and electric (operated with an electric actuator). Available with up to 40 different combinations utilizing the patented “JOK” (Just One Key) system, where the key and locking tumbler are supplied separately from the handle.

### Bus / Motorcoach / Mass Transit

- Access Panels
- Baggage Doors
- Engine Compartments / Hoods
- Exterior Storage Compartments
- Interior Compartments



Prima Product Number	TriMark Part Number	Description
P119	99-51221	Door Handle Manual with Key A-137
P119	99-66129	Handle Manual JOK out

# P141 Locking Door Handle

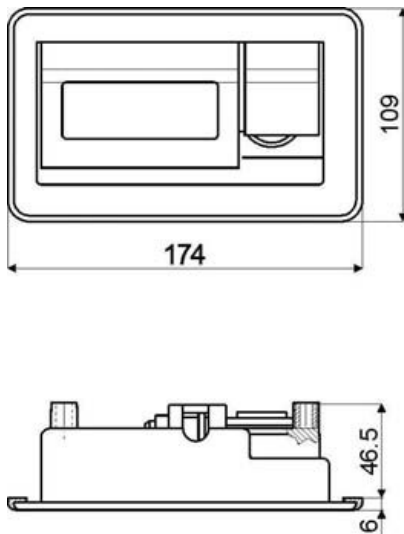

Similar to the P119, this handle offers an open bail handle providing an alternative operating action.

### Bus / Motorcoach / Mass Transit

- Access Panels
- Baggage Doors
- Engine Compartments / Hoods
- Exterior Storage Compartments



Prima Product Number	TriMark Part Number	Description
P141	99-60482	Door Handle Manual With Key A-137
P141	99-63929	Handle Manual JOK
P141	99-69387	Door Handle, Electrical

# P397 Locking Door Handle

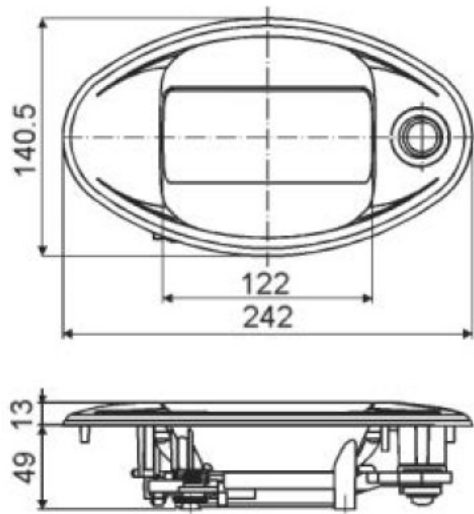

The P397 Locking Handle offers a more streamlined and elegant style, but retains the same basic functions as the P119 handle. Available in manual, pneumatic, and electronically operated models. The P397 is available with the “JOK” (Just One Key) system, where the key and tumbler are supplied separately, allowing up to 40 different lock/key combinations to be available.

### Bus / Motorcoach / Mass Transit

- Access Panels
- Baggage Doors
- Engine Compartments / Hoods
- Exterior Personnel Doors
- Exterior Storage Compartments

Prima Product Number	TriMark Part Number	Description
P397	99-61861	Handle Manual JOK
P397	99-69819	Handle Pneumatic, No Key
P397	99-66391	Gasket



# P183 Flush Compartment Handle

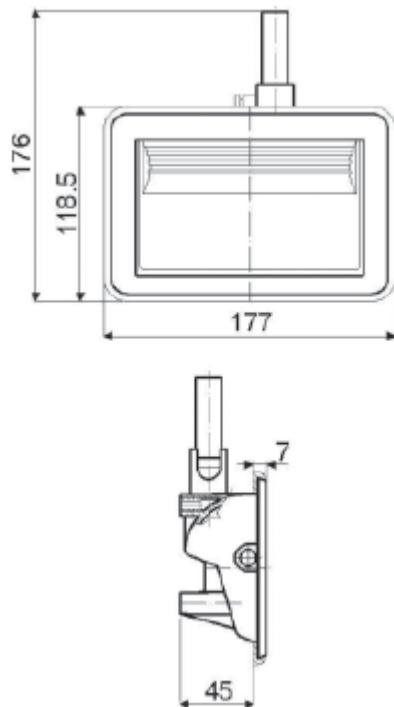

The P183 handle is a standard door handle for use with compartment doors and allows for remote location of a cam lock providing flexibility of key codes. The flush paddle design prohibits water and dirt build-up in finger access, yet provides for ease of opening and pull down of baggage doors. Two point cam provides for single or 2-point connection to latches.



Prima Product Number	TriMark Part Number	Description
P183	99-69767	Handle Manual

# P179 Luggage Compartment Handle

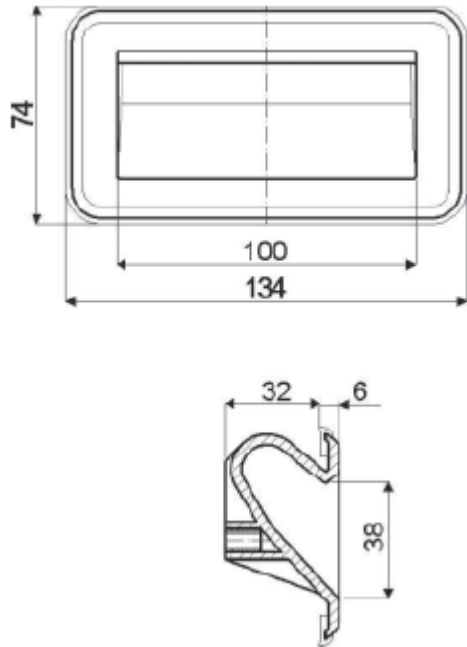

The P179 handle provides a stylish and convenient assist handle for interior and exterior luggage and compartment doors.

### Bus / Motorcoach / Mass Transit

- Access Panels
- Baggage Doors
- Engine Compartments / Hoods
- Exterior Storage Compartments
- Interior Compartments
- Interior Personnel Doors



Prima Product Number	TriMark Part Number	Description
P179	99-65737	Door Handle Cup Style

# P332 Locking Door Handle

The P332 Handle is designed for large pull down baggage doors and features a very robust molded handle for closing. This product can be supplied to work with a single latch all the way up to 4 latches. Available only in pneumatic operated versions. The P332 is available with the "JOK" ("Just One Key") system, where the key and tumbler are supplied separately, allowing up to 40 different lock/key combinations to be available.

### Bus / Motorcoach / Mass Transit

- Access Panels
- Baggage Doors
- Engine Compartments / Hoods
- Exterior Storage Compartments

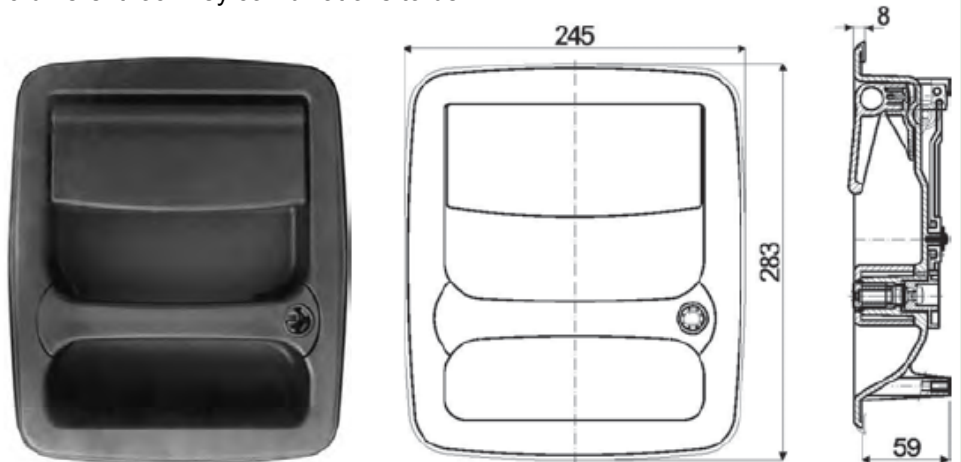

Prima Product Number	TriMark Part Number	Description
P332	99-63969	Handle PN JOK

## P61 Driver's Door Handle

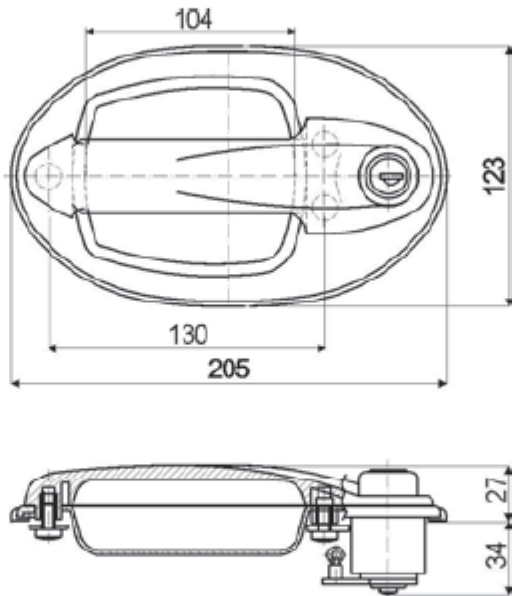

The P61 Push Button Handle is designed to work directly with P62 Forked Lock with Logic providing a driver's door solution. The P61 is available with the "JOK" ("Just One Key") system, where the key and tumbler are supplied separately, allowing up to 40 different lock/key combinations to be available.

### Bus / Motorcoach / Mass Transit

- Exterior Personnel Doors



Prima Product Number	TriMark Part Number	Description
P61	99-69857	Driver's Door Handle With Key A-137

## P203 Lav Door Handle

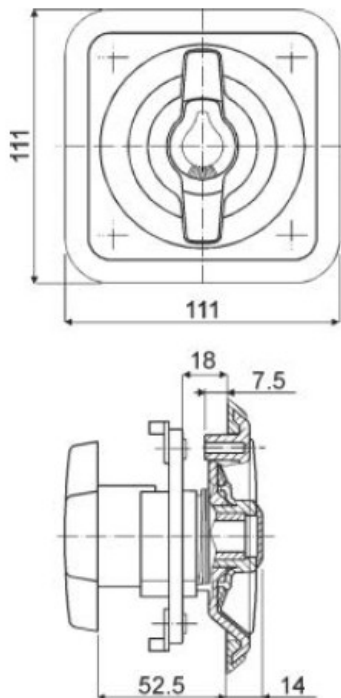

Perfect for interior or exterior door applications that require a locking handle. Locking hardware and latches are also available to provide a complete locking hardware solution. This handle is UV-protected to withstand the elements for exterior use.

### Bus / Motorcoach / Mass Transit

- Exterior Personnel Doors
- Interior Personnel Doors



Prima Product Number	TriMark Part Number	Description
P203	99-67777	Door Handle Lavatory With Key A-137

# P230 Electronic Door Handle



The P230 Electronic Door Handle is a sophisticated locking door handle that utilizes micro switch technology for locking status and door-opening functions. The P230 comes in three different models, each with different characteristics...Manual, Electric, Electro-Pneumatic operational.

Featuring UV protection and can be ordered in up to 40 different locking combinations, employing the patented JOK (“Just One Key”) concept.

**Bus / Motorcoach / Mass Transit**

- Exterior Personnel Doors

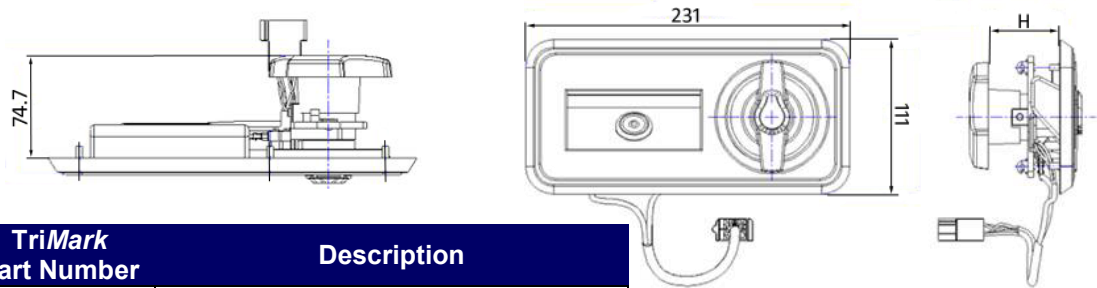

Prima Product Number	TriMark Part Number	Description
P230	99-67977	Entry Door Handle (E) Key A-137
P230	99-63959	Door Handle (E) JOK
P230	99-60898	Four-way Female Faston Connectors
P230	99-66989	Grommet for Switch Cover
P230	99-69128	Micro Switch

	m	e	epn
H	53	53	69

# P247 Emergency Door Handle



The P247 Emergency Handle is for use with emergency egress doors. Made from sturdy polyamide, the handle grip is molded in bright red color for easy visibility. Once pulled, the handle locks in place to prevent accidental re-latching. The base of the handle features a hole for a break-away wire seal.

**Bus / Motorcoach / Mass Transit**

- Interior Personnel Doors

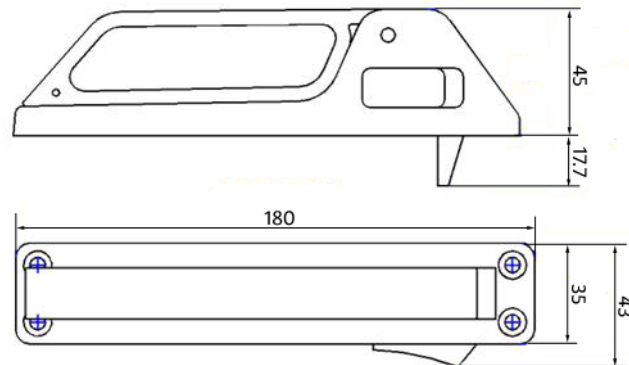

Prima Product Number	TriMark Part Number	Description
P247	99-62178	Emergency Door Handle



# P117 Locking Pin

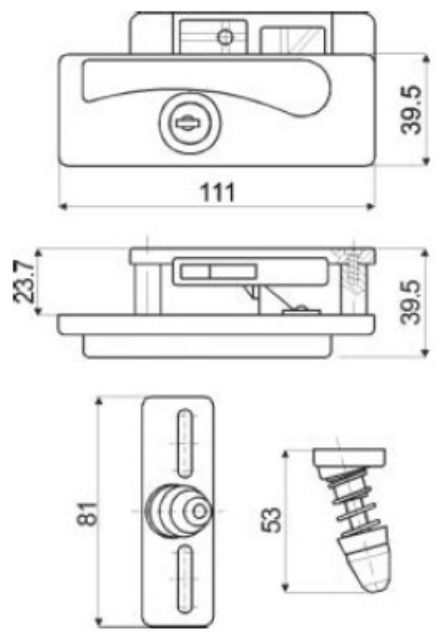

The P117 Locking Pin is a pin style lock designed for bottom hinged interior overhead compartments and is available in both locking and non-locking versions.

**Bus / Motorcoach / Mass Transit**

- Access Panels
- Baggage Doors
- Engine Compartments / Hoods
- Exterior Storage Compartments
- Interior Compartments



Prima Product Number	TriMark Part Number	Description
P117	99-66287	Locking Pin

# P246bis Door Handle

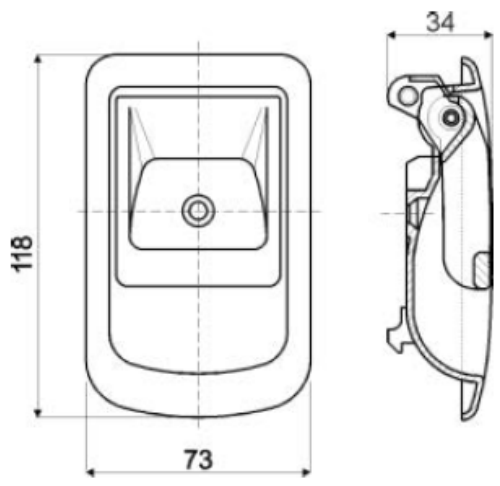

The P246bis Door Handle is the ideal choice for any interior door application. Constructed from durable PA6 plastic, the P246bis Door Handle is also UV-resistant so it is protected from the elements. Locking hardware and latches are also available for a complete installation.



Prima Product Number	TriMark Part Number	Description
P246bis	99-68138	Interior Handle

# P474 J.O.K. Lock/Key Set



Most of the locking door handles from Prima utilize the patented P474 “Just One Key” system. With the JOK system, handles and lock components are supplied separately and can be installed with ease. Allows every lock on a bus accessible with just one key. Up to 40 different key/lock combinations are available.

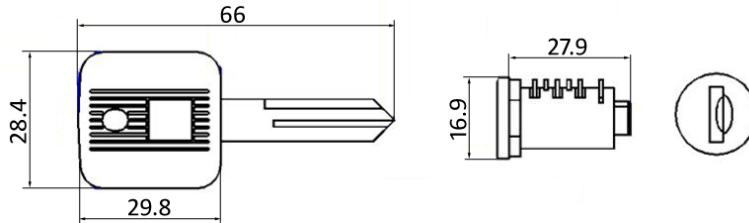

Prima Product Number	TriMark Part Number	Description
P474	99-63999	Tumbler With Key A-137
P474	99-69209	Lock Barrel and Key JOK - PS200

**NOTE:** to be used only with P53J lock and the handles J.O.K. version.

# P70 Forked Lock Latch

This heavy duty lock is ideal for bus and coach compartment doors. It's zinc-plated finish prevents corrosion while an integrated lubrication fitting makes maintenance easy and ensures long life. Works in conjunction with the P70bis and the P130 Control Pin.

### Bus / Motorcoach / Mass Transit

- Access Panels
- Baggage Doors
- Engine Compartments / Hoods

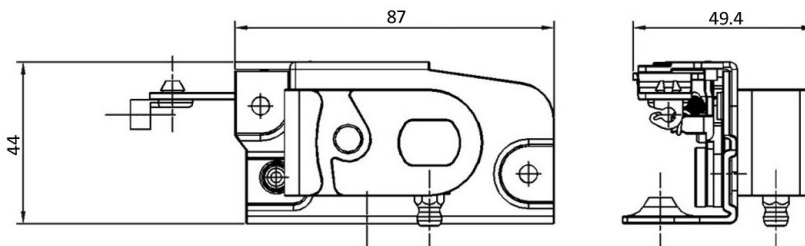

Prima Product Number	TriMark Part Number	Description
P70	99-51700	Forked Lock LHS
P70	99-66940	Forked Lock RHS
P70n	99-64957	Fork Lock LHS With Grease Nipple
P70n	99-64967	Fork Lock RHS With Grease Nipple

## P62 Forked Lock with Logic

The P62 Lock is similar to P70, except that it contains a latch/ logic to work in conjunction with the P61 Drivers Door Handle providing a drivers door solution.

### Bus / Motorcoach / Mass Transit

- Interior Personnel Doors

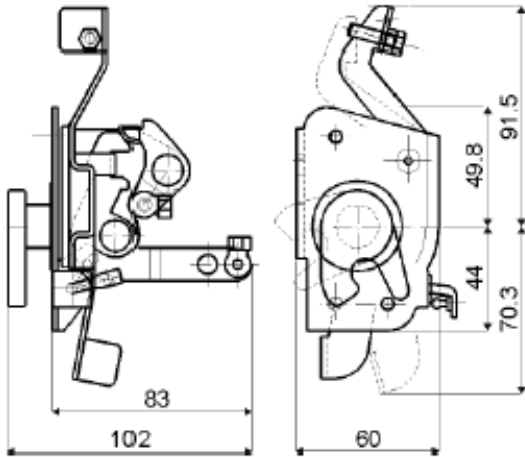

Prima Product Number	TriMark Part Number	Description
P62	99-69687	Drivers Door Lock RHS
P62	99-69697	Drivers Door Lock LHS

## P130 Control Pin with Slot

The control pin is made to work with the P70 Forked Lock Latch and features slotted mounting holes to allow for adjustment.

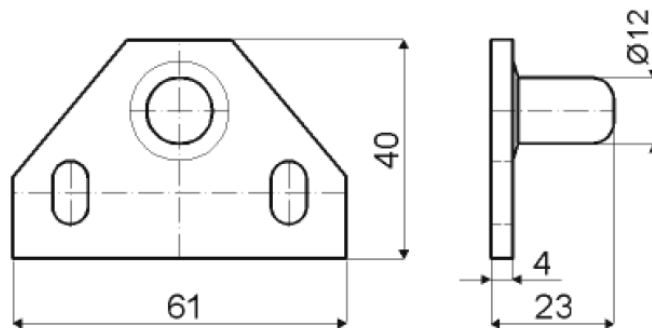

Prima Product Number	TriMark Part Number	Description
P130	99-56521	Control Pin With Slotted Holes
P130	99-52121	Control Pin With Mounting Holes

# P70bis Control Pin

The P70bis Control Pin is designed to work with the P70 Forked Lock. It is made of zinc-plated steel and is available in 10 and 12mm pin diameters.

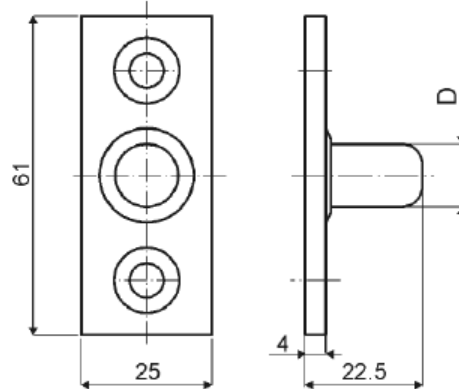

Prima Product Number	TriMark Part Number	Description
P70bis	99-64981	Control Pin 12mm

# P271 Clasp Lock

The P271 Clasp Lock is designed for side and rear access doors where an over-center lock push with to close and pull to open functionality is desired.

**Bus / Motorcoach / Mass Transit**

- Access Panels
- Baggage Doors
- Engine Compartments / Hoods
- Interior Compartments

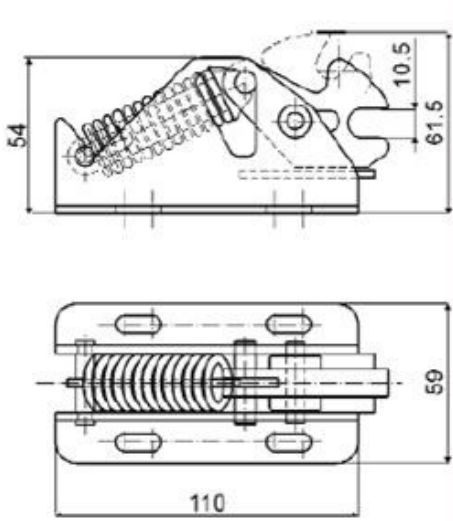

Prima Product Number	TriMark Part Number	Description
P271	99-62238	Clasp Lock 10mm

## P238 Locking Pin



The P238 Locking Pin is ideal for any door lock system. It features a durable, corrosion-resistant zinc-plated steel pin and an attached rotating rod clip.

### Bus / Motorcoach / Mass Transit

- Interior Personnel Doors

Prima Product Number	TriMark Part Number	Description
P238	99-67967	Locking Pin

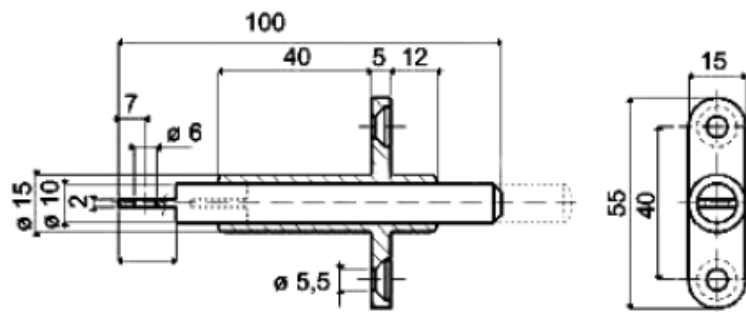

## P301 Pin Strike



The P301 Pin Strike is designed for use in pantograph style luggage doors to retain the bottom of door, allowing the top to tip -in and secure.

### Bus / Motorcoach / Mass Transit

- Baggage Doors
- Exterior Storage Compartments

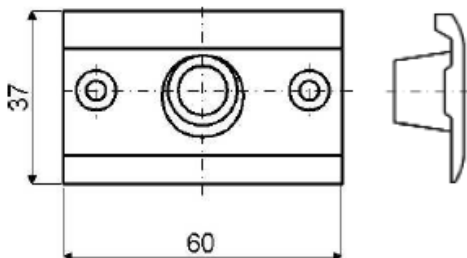

Prima Product Number	TriMark Part Number	Description
P301	99-65628	Pin Vanger

## P144 Lock Cover

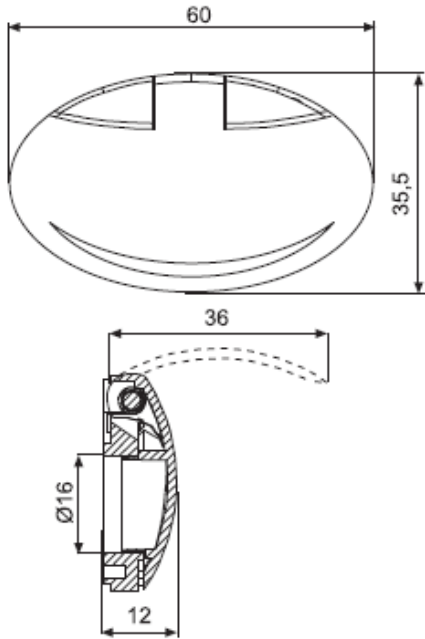

The P144 Lock Cover is the perfect choice for battery compartments, maintenance hatches, or any other exterior door. Its polyamide fiberglass construction offers superior weather protection, while its stainless steel pin and spring ensure a lifetime of reliable use. Mounts easily over any lock with two self-tapping screws (not included).



Prima Product Number	TriMark Part Number	Description
P144	99-62853	Flap Lock Cover (Rect)
P144	99-65631	Flap Lock Cover (Oval)

## P59 Sliding Window Knob

The P59 Sliding Window Knob is designed to provide a means of moving a sliding window. It installs into a 12.5mm hole through the glass and will work with glass thickness of 2-12mm.

### Bus / Motorcoach / Mass Transit

- Window Systems

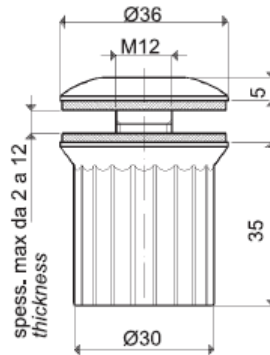

Prima Product Number	TriMark Part Number	Description
P59	99-65357	Sliding Window Knob

# P76 Sliding Window Lock

The P76 Sliding Window Lock is designed to secure sliding windows and releases easily by squeezing the 2 tabs together which raises the pin out of window hole. It is easy to install and fasteners are included.

**Bus / Motorcoach / Mass Transit**

- Window Systems

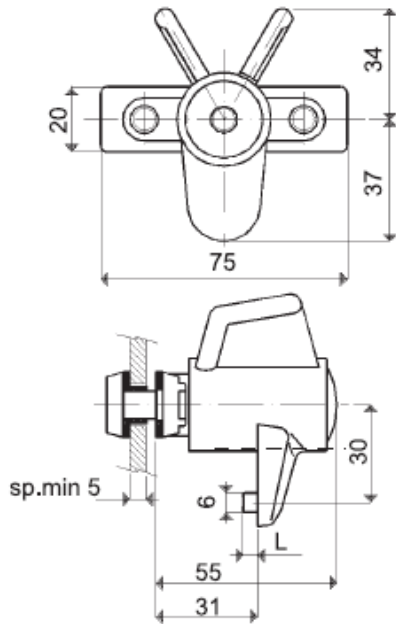







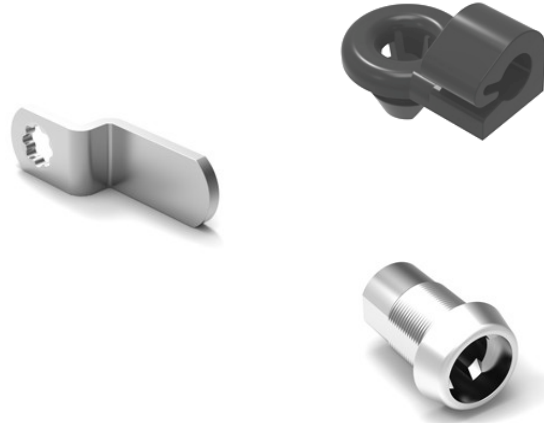

Prima Product Number	TriMark Part Number	Description
P76	99-65397	Sliding Window Lock

# Accessories

A variety of accessories are available to provide a complete access solution. These include gaskets, fasteners, rods and clips, mounting brackets, cam locks and cams, keys, wiring harness, etc. (please inquire.)



Prima Product Number	TriMark Part Number	Description
P73 	99-55824	Replacement Key A-137
P94 	99-65437	Connector Clip for Handles
P53j 	99-65639	Cylinder Casing JOK for tumbler
P53j	99-68541	Escutcheon, Key Lock
P303 	99-65898	Clamping Lug for P247
P303 	99-65918	Set Screw for P247
P221 	99-67009	Locking Plate
P221j	99-65749	Key Lock Cam
P000 	99-67027	Cam for P119 and P141
P242 	66-69547	Mounting Plate with 4 Spacers
P000 	99-62768	Replacement knob for P203 / P230



# 120-1000 ClassicDOOR Hinge System

The ClassicDoor pantograph hinge system is a pre-engineered solution to provide kitted components that simplify the design, fabrication, assembly and opening of bus and motor coach luggage compartment doors. Variables to determine the proper kits; are the weight of the door, width of the door and the height that the door travels vertically. The following are the components that make-up the kits:

- Tube Assemblies
- Lever Arms
- Brackets and Struts
- Gas Shocks

## Designed For

- Medium to heavy-duty bus and motor coach pantograph hinge style luggage doors
- Door weights of 30-80 Kg (66-175 lbs.)
- Door heights between 750-1500mm (29.5-59.0in.)

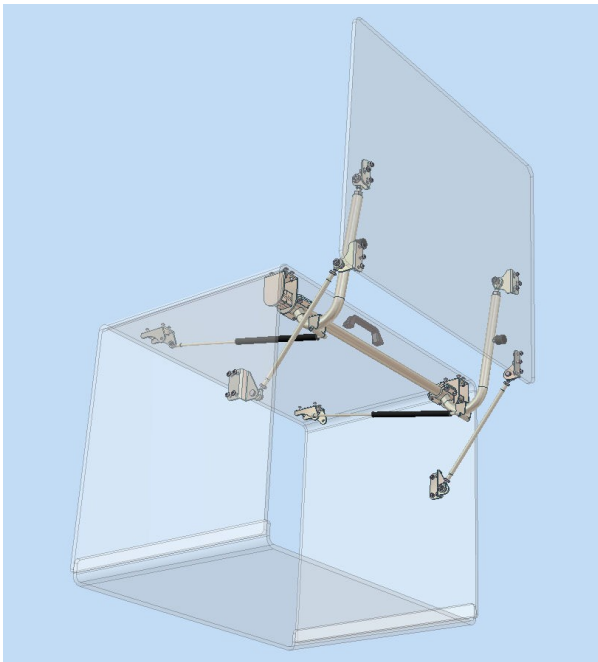
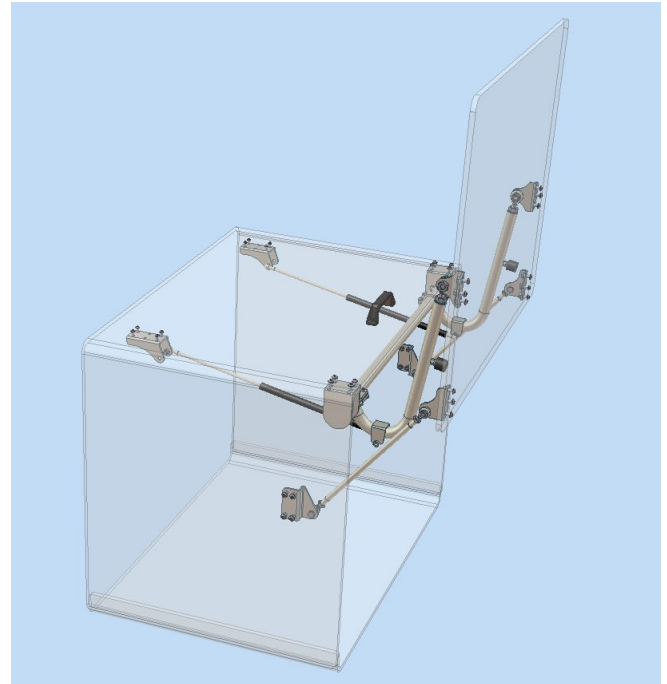

## Features/Benefits

- Select from pre-engineered components and sub-assemblies to simplify the design and installation
- The robust Tube Assemblies and Lever Arms ensure smooth operation and the Struts and Gas Shocks provide stability and balance to the door operation.

## Available

- TriMark can provide the entire hinge system or select components that are application matched to ensure balanced, smooth and safe operation.

# Full System Solutions

The following are TriMark products that could be used in conjunction with Prima products to provide a complete access solution. Please inquire for application assistance.



## 030-2000 Two-Point Free-Float Baggage Lock

Designed for baggage doors, this product is available in black or copper-nickel-chrome plated finish and features a two-point bell crank for remote actuation and is power lockable.

## 040-1400 Push Button Actuator

This Push Button Center Control features KeyOne™ Plus keying in a push button actuation and a 2-point bell crank linkage.

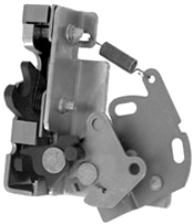

## 050-0250 Single Rotor Latch & Linkage Assembly

This latch and linkage system is intended for occupant or exit/entry doors that require compliance to FMVSS 206 standards. The flexible design allows for internal or external door mounting and provides automotive logic function with remote activating handles.

## 050-0500 Single Rotor Mini-Latch

Designed for small compartment and access doors where low cost slam action latching is desired. It features a single or 2 position compact rotary and is available in a variety of trip levers and mounting axles for ease of mounting and applications.



## 550-0100 Power Lock Actuators

TriMark has several high quality power door lock actuators available with a variety of features and configurations. The actuators have been tested and validated to meet stringent requirements thus ensuring a long life of trouble free operation.

## 500-1200

The integration of mechanical handles/latches and keyless-entry electrical products is available with TriMark's e-ASK System. This integrated system offers increased security, convenience and functionality with reduced system installation complexity and lower installation costs for demanding users of RVs, heavy trucks, emergency vehicles, agricultural and construction equipment.



## 090-0150 Rods

Multiple bend capability including compound bend angles. Available in pre-plated steel rod diameters: .125 (3.2mm), .168 (4.3mm), .214 (5.4mm), and .390 (9.9mm). Other rod diameters are available (please inquire).

---

---

# Notes



**TriMark Corporation**  
500 Bailey Avenue ~ P.O. Box 350  
New Hampton, IA 50659 ~ United States  
Tel: +1 641 394 3188 ~ Fax: +1 641 394 2392  
[www.trimarkcorp.com](http://www.trimarkcorp.com)