

Table of Contents

Latches Page

Slam Action (hook, pivoting & rotating catch)

030-0500 Pivoting Catch Compartment Latch.....	36
030-0550 Heavy Duty Pivoting Catch Compartment Latch	37
030-0600 Rotating Catch Compartment Latch	38
030-0625 2-Point Rotating Catch Compartment Latch.....	38
030-1125 Paddle Handle With Hook.....	39
050-1300 Plastic Slam Latch	40



Compression

080-0200 Lever Style Compression Latch	41
080-0400 CompOne™ Compression Latch	42

Over-Center

090-0500 Window Hold-Open.....	43
090-0520 Window Hold-Open.....	43

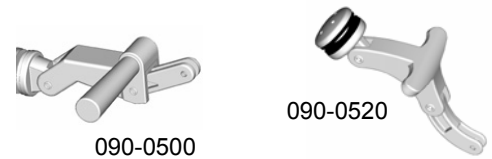

Pin Type

130-0100 Dual Release Door Hold-Open	44
130-0110 Single Release Door Hold-Open.....	45



Handles Page

Paddle

030-0100 Single Rotor Compartment Latch	46
030-0150 Heavy Duty Compartment Latch.....	47
030-0175 Stamped Steel Compartment Latch	48
030-0185 Stamped Steel 2-Point Paddle Handle	49
030-0200 Paddle Handle	50
030-0250 Paddle Handle With Inside Release Lever	50
030-0800 Flush Mounted Paddle Handle	51
030-0825 Flush Mounted Paddle Handle With Inside Release.....	52
030-0850 Flush Mounted Paddle Handle	53
030-0860 Flush Mounted Paddle Handle With Inside Lock Knob .	54
030-0875 Free-Float Flush Mounted Paddle Handle	55
030-0900 Motor Home Entrance Door Hardware With Dead Bolt.	56
030-1000 Motor Home Entrance Door Hardware.....	57
030-1050 Motor Home Entrance Door Hardware With Dead Bolt.	57
030-1100 2-Point Paddle Handle	58
030-1125 Paddle Handle With Hook.....	59

Table of Contents

Handles

Page

Paddle—Cont.

030-1200 Round Paddle Handle	60
030-1300 D-Paddle Handle	62
030-1400 Paddle Handle	63
030-1425 Inside Bezel & Release Lever Assembly.....	64
030-1450 Two-Point Paddle Handle.....	65
030-2000 Two-Point Free Float Baggage Lock.....	66
030-2100 Stamped Steel 2-Point Paddle Handle.....	67
030-2300 Wedge Paddle Handle.....	68
060-0201 Trailer Latch.....	69
060-0251 Trailer Latch With Dead Bolt.....	69
060-0460 EZ Access Baggage Door Lock	70
060-0475 Flush Baggage Door e-LOCK.....	71
060-0600 Motor Home Entrance Door Hardware.....	72
060-0650 Motor Home Entrance Door Hardware With Dead Bolt.	72



Pull Type

020-0700 Flush Pull Handle	73
020-0800 Surface Mounted Pull Handle.....	74
020-0850 e-LOCKING Pull Handle.....	75
020-1100 Remote Pull Handle.....	76
020-1150 Two-Point Free Float Pull Handle	77

Push Button

040-0100 Push Button Handle.....	78
040-0300 Non-Metallic Push Button Handle	79
040-0600 TriMount Push Button Handle	80
040-0700 Lift and Latch Handle.....	81
040-1400 Push Button Center Control.....	82

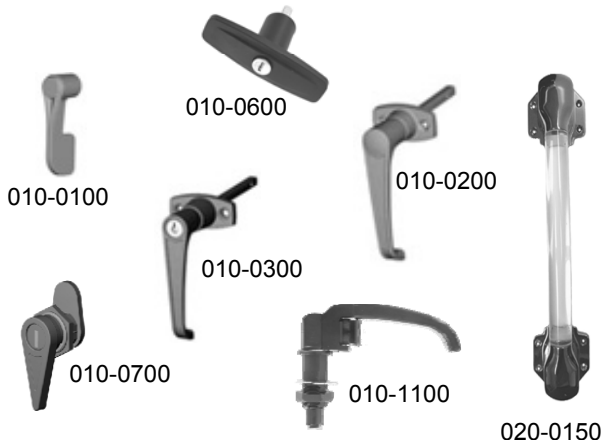

Rotating T & L

010-0100 Release Lever	83
010-0200 Non-Locking L-Handle.....	84
010-0300 Locking L-Handle	84
010-0600 Flush Mounted Pop-Up T-Handle.....	86
010-0700 Light Duty Compartment Latch.....	87
010-1100 TriGuard Heavy Duty Rotating Handle.....	88

Grab

020-0150 Grab Handle	89
----------------------------	----

030-0100 Single Rotor

Designed for most medium to heavy-duty storage and compartment doors, this product features an integrated rotary latch for ease of installation and use.

- On or off-highway vehicle applications--construction, mining, agricultural
- Service and utility truck body doors
- Fire and rescue unit vehicles
- Most storage, compartment and access doors with latch and strike location at top or sides of door
- Door weights of approximately 75 lbs. (34 kg) or less

AVAILABLE:

- Keyed alike with shuttered keyway, key code LL11
- Keyed random
- Padlockable

MATERIAL:

- Housing and paddle: die cast zinc alloy
- Other components: zinc plated, mild steel
- Internal latch components: case hardened, smooth edge stamped steel



FINISH:

- Clear chromate, ready to paint
- Buffed copper-nickel-chrome plated
- Buffed duplex nickel

INTERNAL LUBRICATION:

- Oven-cured dry lubricant is applied on all critical moving parts

INSTALLATION:

- 3/16" (4mm) diameter fasteners

CAUTION: Compartment latch does not meet FMVSS 206 load requirements.

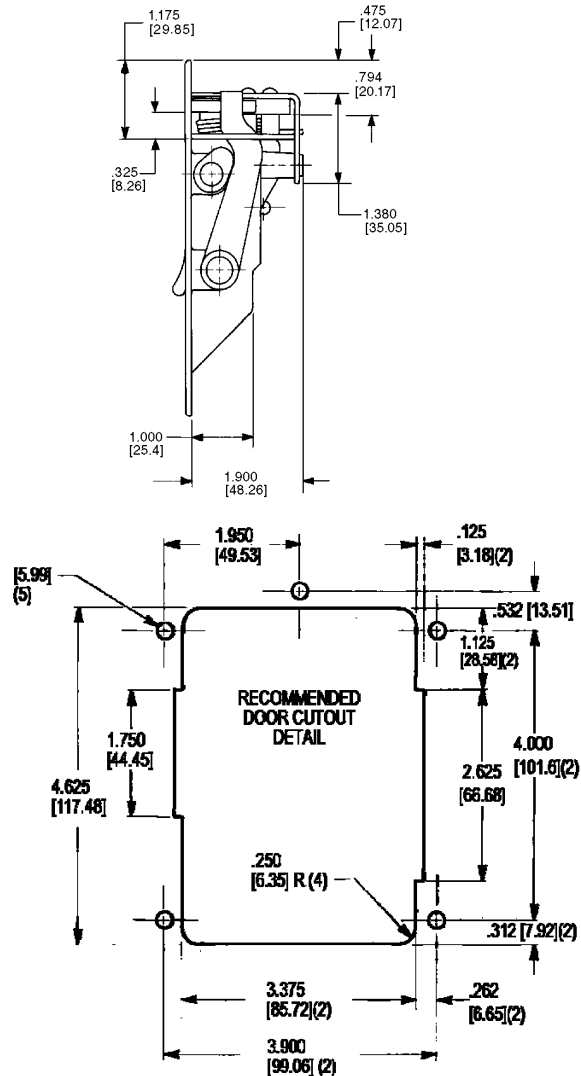
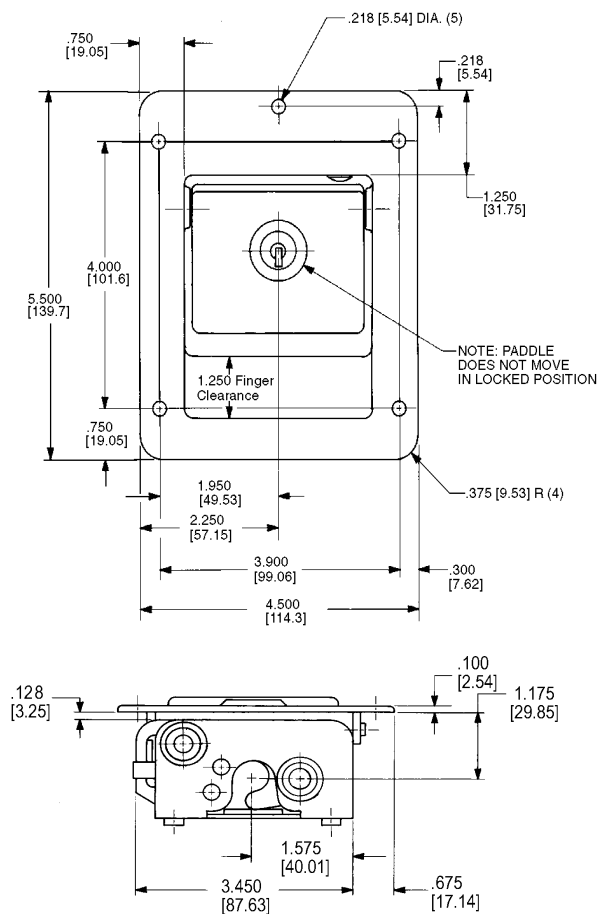

For more information visit
www.trimarkcorp.com

Handles:
Paddle

46

TriMark
www.trimarkcorp.com

030-0150 Heavy Duty Compartment

Designed for most medium to heavy-duty storage and compartment doors, this product features an integrated rotary latch for ease of installation and use.

- On or off-highway vehicle applications--construction, mining, agricultural
- Service and utility truck body doors
- Fire and rescue unit vehicles
- Most storage, compartment and access doors with latch and strike location at top or sides of door
- Door weights of approximately 75 lbs. (34 kg) or less

AVAILABLE:

- Keyed alike with shuttered keyway, key code LL11
- Keyed random
- Padlockable

MATERIAL:

- Housing and paddle: die cast zinc alloy
- Other components: zinc plated, mild steel
- Internal latch components: case hardened, smooth edge stamped steel



FINISH:

- Clear chromate, ready to paint
- Buffed copper-nickel-chrome plated
- Buffed duplex nickel

INTERNAL LUBRICATION:

- Oven-cured dry lubricant is applied on all critical moving parts

INSTALLATION:

- 3/16" (4mm) diameter fasteners

CAUTION: Compartment latch does not meet FMVSS 206 load requirements.

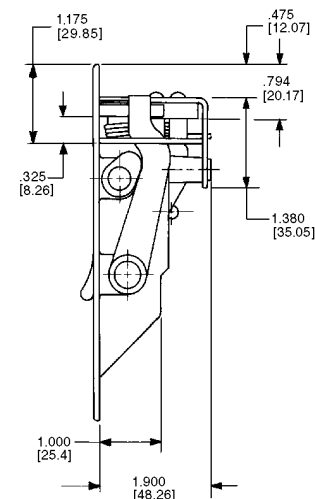
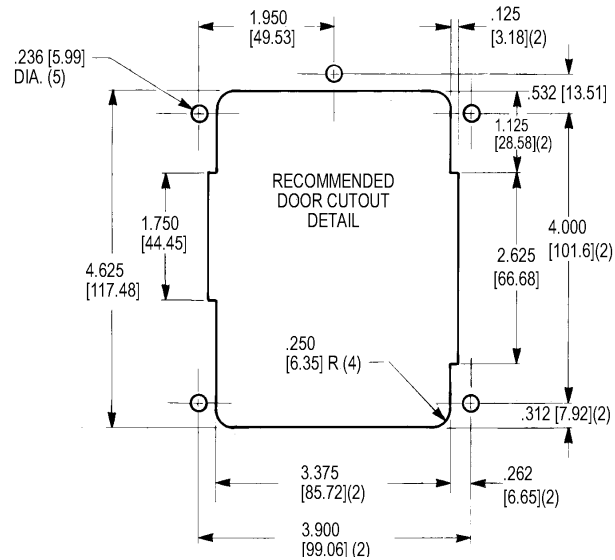
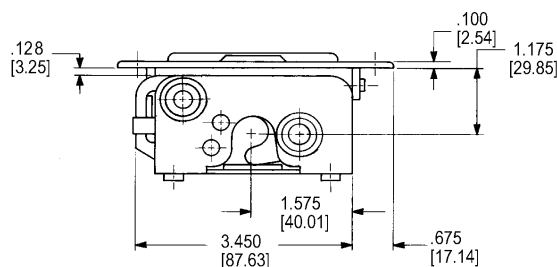
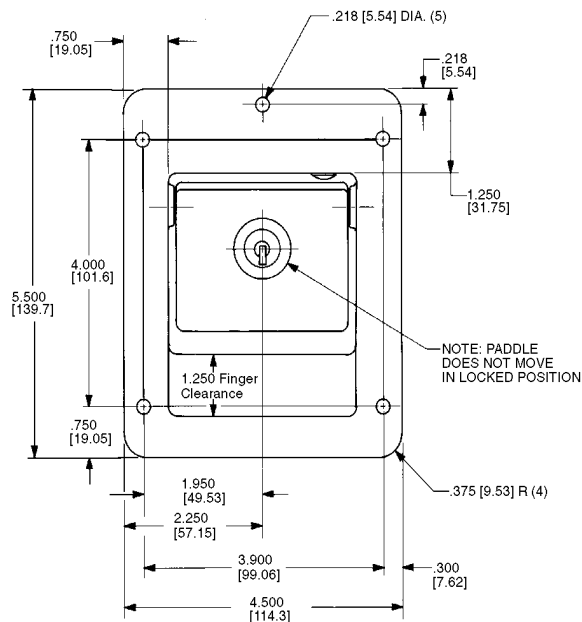

030-0175 Stamped Steel Compartment Latch

This compartment latch was designed for light to medium duty storage and compartment doors. Available in buffed stainless steel or plated mild steel, this product features an integrated rotary latch for ease of installation and use and is available in a power lockable version.

- On or off-highway vehicle applications
- Service and utility truck body doors
- Fire and rescue unit vehicles
- Most storage, compartment and access doors with latch and strike location at top or sides of door
- Door weights of approximately 75 lbs. (34 kg) or less

AVAILABLE:

- In locking or non-locking configurations
- Keyed alike
- Keyed random. 50 key codes available
- 2-point pivot plate for doors that require a 2-point latching mechanism (030-0185)
- Optional gasket for flange of housing is available to provide resistance to water and dirt infiltration
- Power lock actuation
- Customer logo on paddle (please inquire)

FINISH:

- Buffed and polished stainless steel
- Zinc plate clear chromate conversion coat over mild steel for maximum paint adhesion and resistance to rust

MATERIAL:

- Housing and paddle: 300 series stainless steel
- Mild steel also available on housing and paddle
- Other components: zinc plated, mild steel
- Internal latch components: case hardened, smooth edge stamped steel
- Stainless steel non-corrosive springs and rivets



INSTALLATION:

- 3/16" (4mm) diameter fasteners
- Blind mount option also available

APPLICATION RECOMMENDATIONS:

- Striker bolt installation should allow for a minimum radial movement of .060 (1.524) for adjustment
- Rubber bumpers or door seals are recommended to reduce effects of vibration stress on door and latch system

CAUTION: Compartment latch does not meet FMVSS 206 load requirements.

U.S. Patent No. 5,299,844

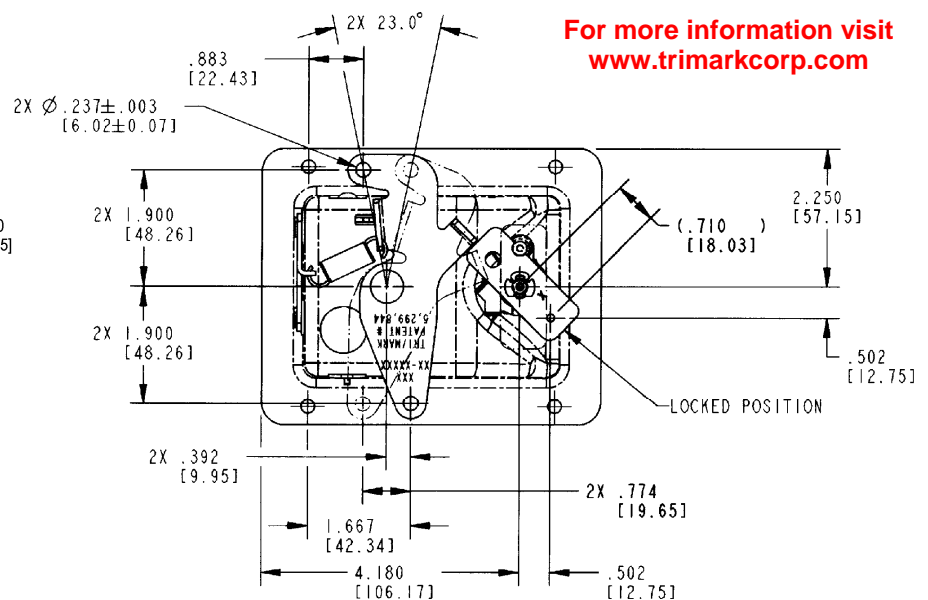
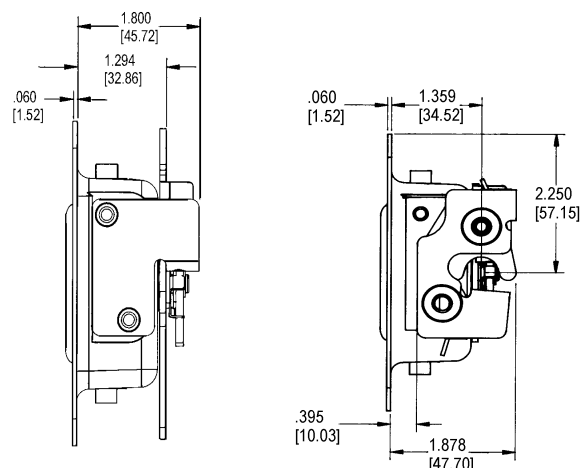
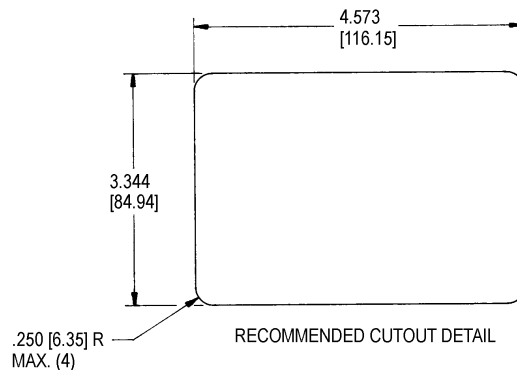

For more information visit
www.trimarkcorp.com

Handles:
Paddle
48

TriMark
www.trimarkcorp.com

030-0185 Stamped Steel 2-Point Paddle Handle

This compartment latch was designed for light to medium duty storage and compartment doors. Available in buffed stainless steel or plated mild steel, this product features a 2-point bellcrank for remote actuation and is power lockable.

- On or off-highway vehicle applications
- Most storage, compartment and access doors with single or 2-point latch actuation

AVAILABLE:

- In locking or non-locking configurations
- Keyed alike
- Keyed random. 50 key codes available
- Optional gasket for flange of housing is available to provide resistance to water and dirt infiltration
- Power lock actuation

FINISH:

- Buffed and polished stainless steel
- Zinc plate and clear chromate conversion coat over mild steel for maximum paint adhesion and resistance to rust



MATERIAL:

- Housing and paddle: 300 series stainless steel
- Mild steel also available on housing and paddle
- Stainless steel non-corrosive springs and rivets
- Other components: zinc plated, mild steel

INSTALLATION:

- 3/16" (4mm) diameter fasteners
- Front view and recommended door cut-out detail same as 030-0175 Stamped Steel Compartment Latch
- Blind mount option available

U.S. Patent No. 5,299,844

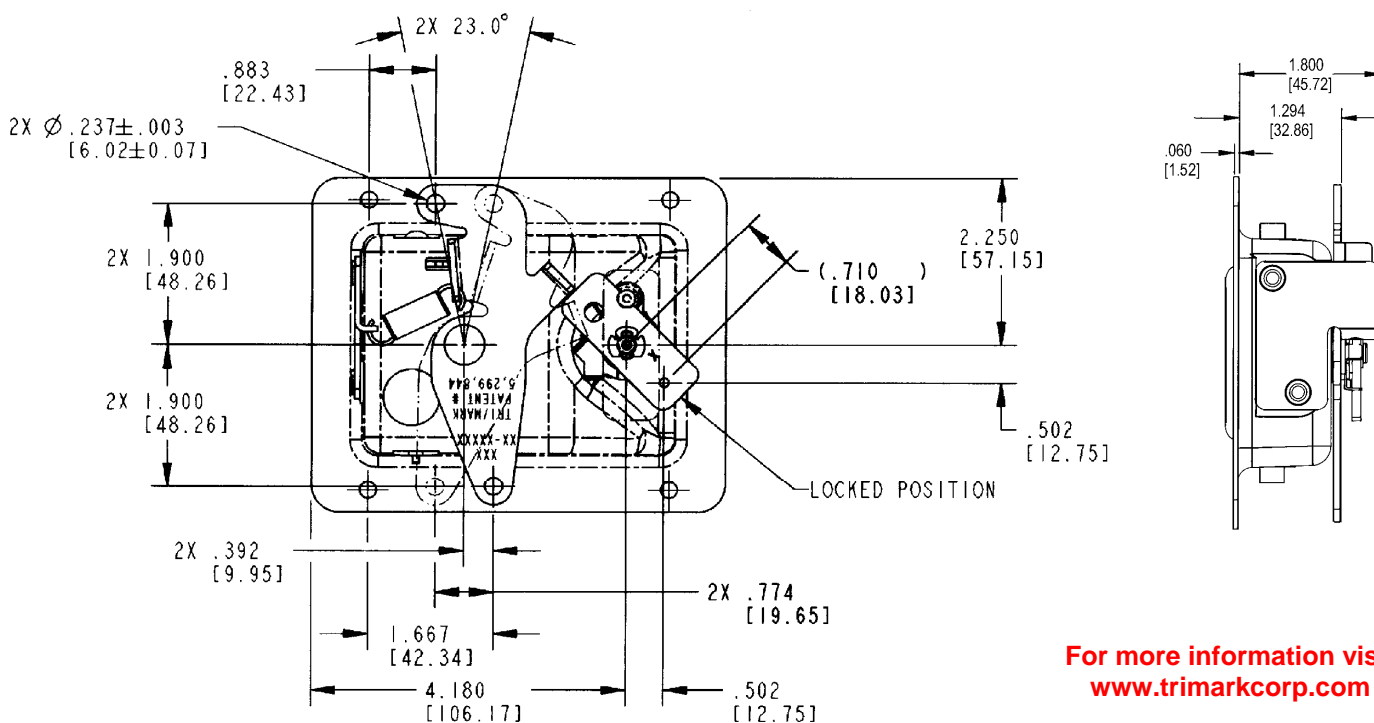

For more information visit
www.trimarkcorp.com

030-0200 / 030-0250 Paddle Handle

This flush paddle was designed for heavy-duty off-highway vehicle entrance doors and features robust construction and pivot plate versatility.

- Off-highway vehicle applications - construction, mining, agricultural, forestry
- Doors requiring latch location remote from activating handle
- Door thickness of 2" (50.8mm) or greater

AVAILABLE:

- In right or left hand configurations (left hand shown)
- In locking or non-locking configurations

MATERIAL:

- Housing and paddle: die cast zinc alloy
- Pivot components: zinc plated, mild steel

FINISH:

- Housing and paddle: black powder coated
- Copper-nickel-chrome plated



INSTALLATION:

- Four 10-24 UNC or M5 X .8 mounting screws (not included)

NOTE: Mounting bosses are tapped 3/8" deep

CAUTION: Paddle does not comply with locking requirements of FMVSS 206.

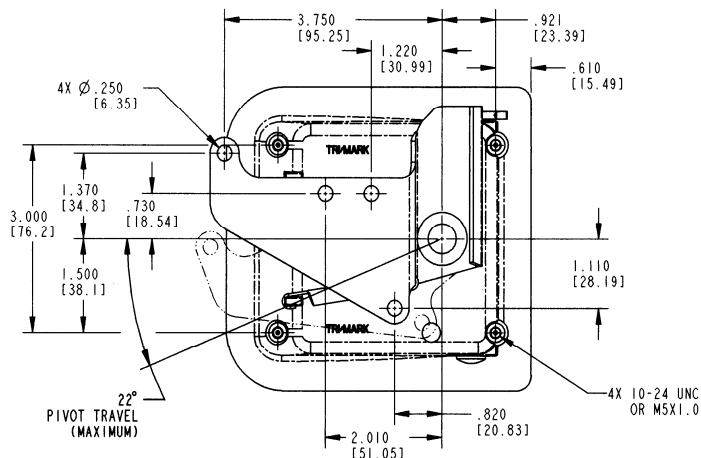

NOTE: PADDLE IS RIGID IN LOCKED POSITION

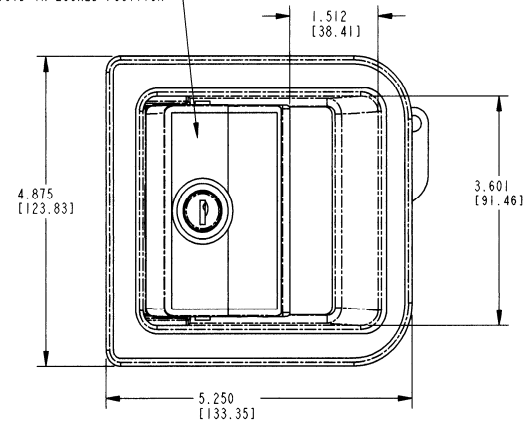

Handles:
Paddle

50

TriMark
www.trimarkcorp.com

030-0825 Flush Mount Paddle Handle With Inside Release Lever

This flush paddle was designed for medium to heavy-duty on-highway vehicle entrance doors and features robust construction and an integrated inside release lever that reduces the need for a separate inside release.

- Off-highway applications--construction, mining, forestry and agricultural
- On-highway--emergency vehicles not requiring FMVSS 206 standards

FEATURES/BENEFITS:

- Mounts in doors requiring latch location remote from activating handle
- Inside release lever eliminates much of the linkage typically required with conventional inside handle
- Operator can exit even if the door is locked from the outside

AVAILABLE:

- In right or left hand configurations (left hand shown)
- Non-locking or locking--keyed alike with shuttered keyway
- Optional pivot plates available for your particular application

INSTALLATION:

- Easily installed with two 1/4-20 UNC mounting screws and brackets (screws and brackets are supplied)



MATERIAL:

- Housing and paddle: sturdy die cast zinc alloy
- Pivot components: zinc plated, mild steel
- Bushing for paddle axle and thrust washers for pivot plate: 6-6 nylon

FINISH:

- Housing and paddle can be finished in your choice of black powder coat or buffed copper-nickel-chrome

CAUTION: Paddle does not meet the locking requirements for FMVSS 206

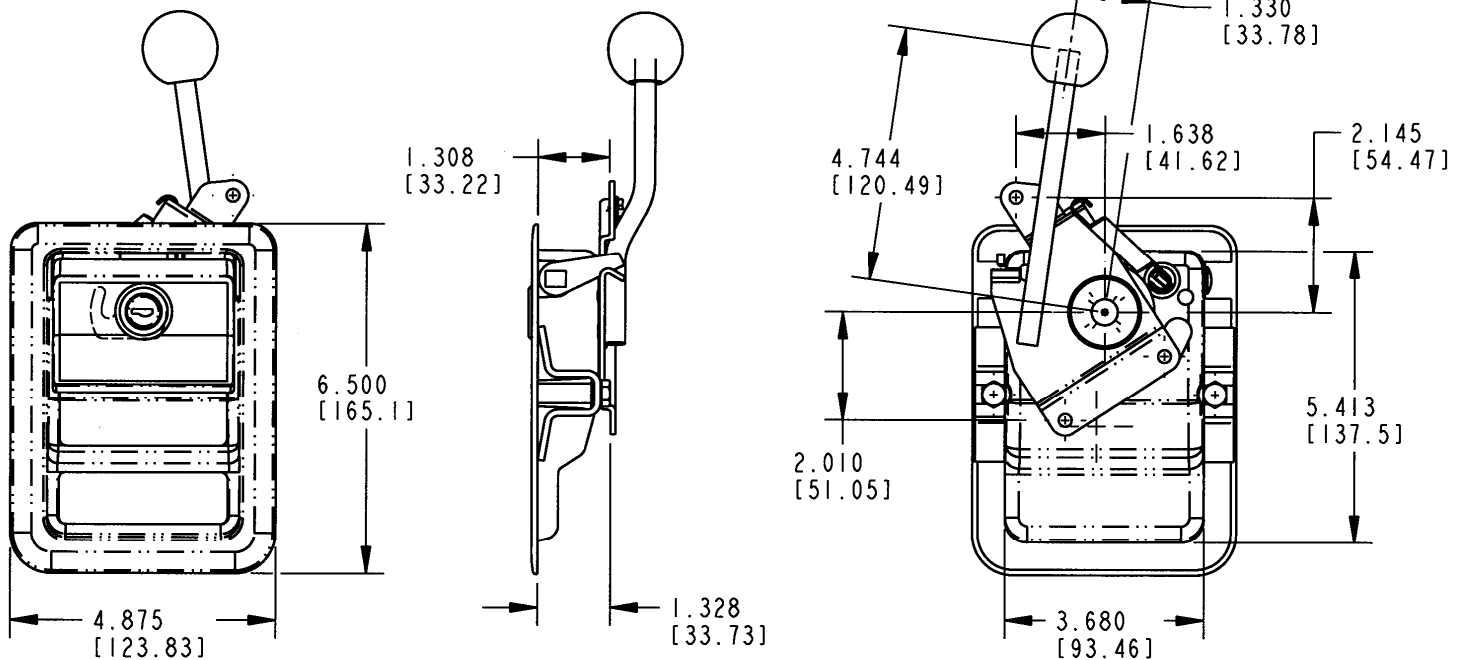

030-0850 Flush Mounted Paddle Handle (FMVSS 206)

This flush paddle was designed for medium to heavy-duty on-highway vehicle entrance doors and features robust construction, a lock detail that allows for power locking and is compliant to FMVSS 206.

FEATURES/BENEFITS:

- Inside lock provides override if outside paddle should be locked
- Paddle is rigid when locked
- Inside lock provides for multiple connection points for use of inside lock and/or powerlock actuation

INSTALLATION:

- Either handed version can be installed in a wide range of locations in door - either horizontal or vertical orientation (left hand shown)

MATERIAL:

- Housing and paddle: zinc die cast alloy
- Pivot components: zinc plated, mild steel
- Bushing for paddle axle and thrust washers for pivot plate: 6-6 nylon

FINISH:

- Black powder coated
- Copper-nickel-nickel-chrome plated
- Combination black powder coated housing and chrome paddle



AVAILABLE:

- Optional gasket for flange of housing is available to provide resistance to water and dirt infiltration
- Keyed random. TM201-TM250
- Keyed alike



NOTE: Meets FMVSS 206 locking requirements and may be used in FMVSS 206 applications pending TriMark application approval.

For more information visit
www.trimarkcorp.com

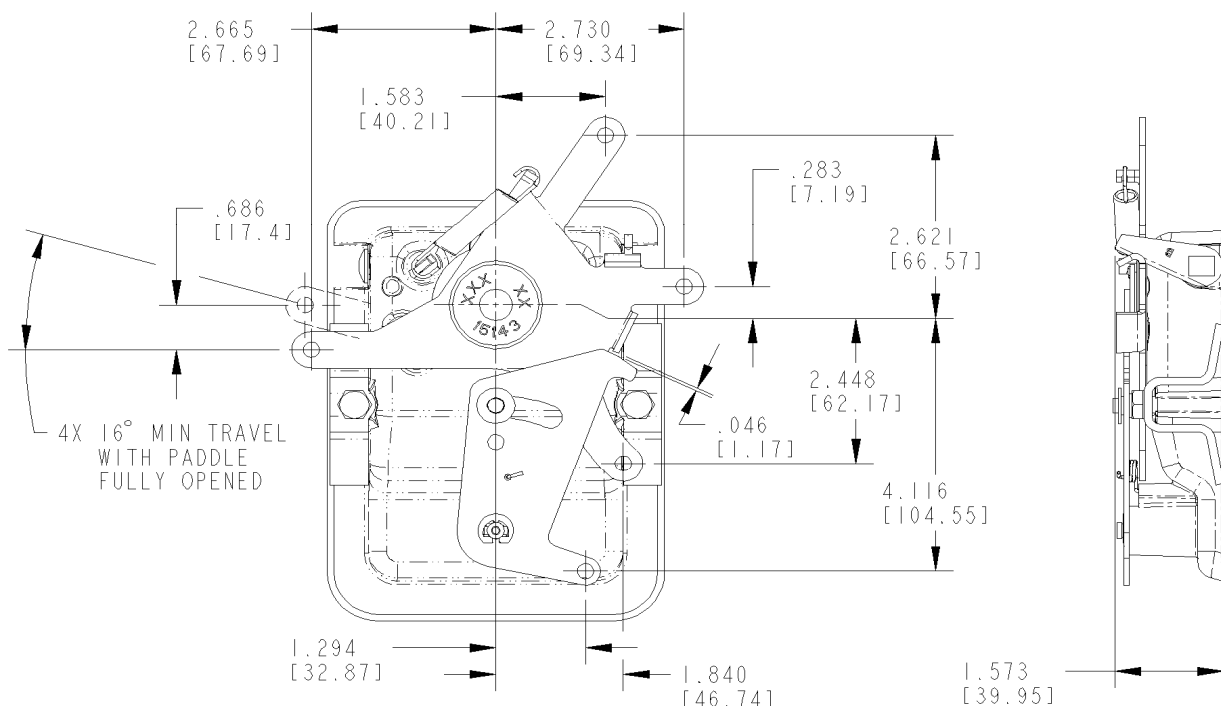

030-0860 Flush Mounted Paddle Handle With Inside Lock Knob

The 030-0860 Flush Mounted Paddle Handle With Inside Lock Knob incorporates the basic material and concepts used in the 030-0800 Flush Mounted Paddle Handle

FEATURES/BENEFITS:

- Inside lock provides override if outside paddle should be locked
- Paddle is rigid when locked

INSTALLATION:

- Either handed version can be installed in a wide range of locations in door--either horizontal or vertical orientation (left hand shown)

MATERIAL:

- Housing and paddle: die cast zinc alloy
- Pivot components: zinc plated, mild steel
- Bushing for paddle axle and thrust washers for pivot plate: 6-6 nylon

FINISH:

- Black powder coated
- Chrome plated



NOTE: Complies with FMVSS when used in conjunction with 030-0850 Flush Mounted Paddle Handle and approved latching mechanisms

Meets FMVSS 206 locking requirements and may be used in FMVSS 206 applications pending TriMark application approval.

For more information visit
www.trimarkcorp.com

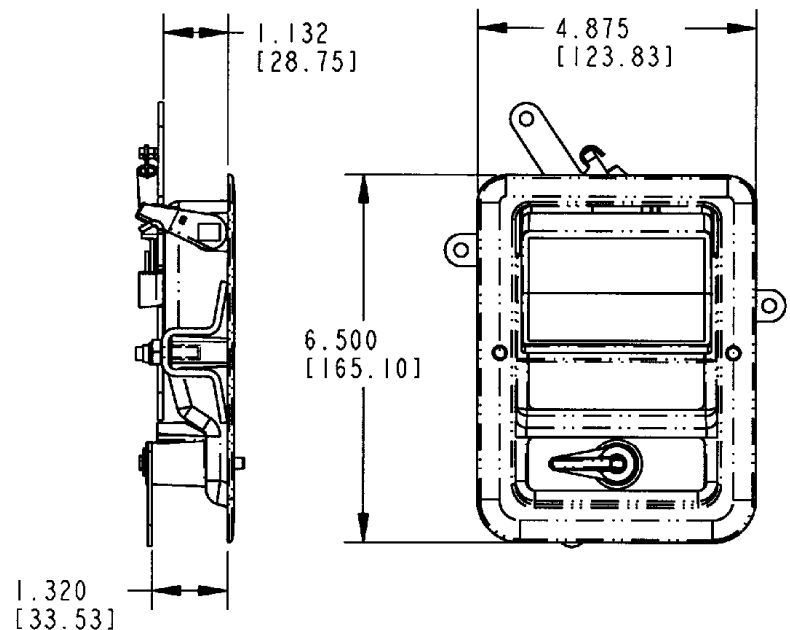
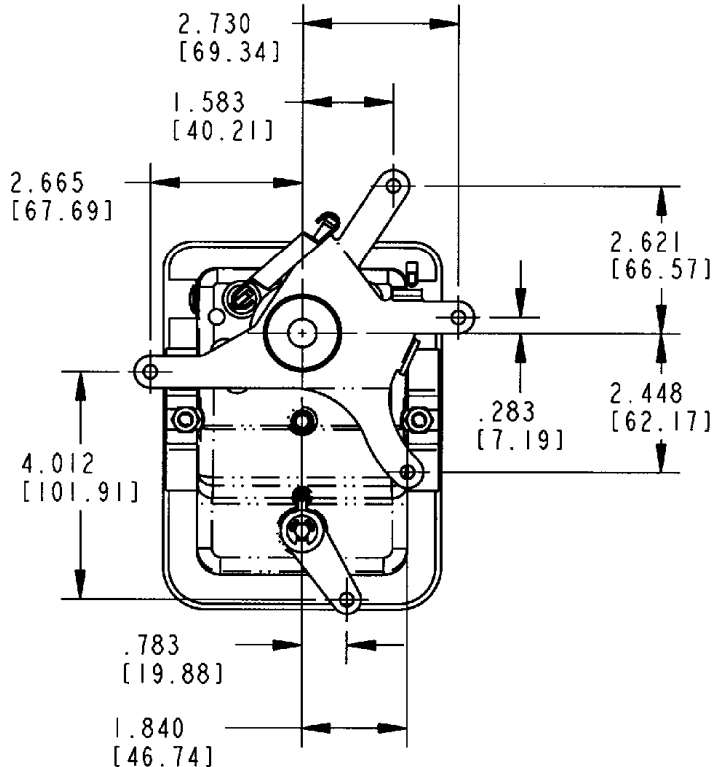

030-0875 Free-Float Flush Mounted Paddle Handle

This flush mounted paddle handle is a redesign of our popular 030-0850 Flush Mounted Paddle Handle. Featuring a free-float paddle in the locked position, this robust product allows for a power locking and is compliant to FMVSS 206.

DESIGNED FOR:

- Medium to heavy-duty on-highway vehicle entrance doors where free-float locking is preferred
- Door weights of 23-455 kg (50-1000 lbs.)

FEATURES/BENEFITS:

- Provides for multiple connection points for use on inside lock and/or power lock actuation
- Inside lock provides override if paddle should be locked
- Handle can be keyed to match other TriMark RV door products with KeyOne Plus for a single-key system or provided non-locking



MATERIAL:

- Paddle and housing: Sturdy die cast zinc alloy
- Pivot components: Zinc plated, mild steel
- Bushing for paddle axle and thrust washer for pivot plate: 6-6 nylon

FINISH:

- Available in a variety of finishes including black powder coated, high quality buffed chrome or a combination of black/chrome finish

AVAILABLE:

- Optional gasket for flange of housing is available to provide resistance to water and dirt infiltration
- Lock can be keyed to match other TriMark door products with KeyOne Plus for a single-key system, keyed alike or provided non-locking



INSTALLATION:

- Either hand version can be installed in a wide range of locations in door -- either horizontal or vertical orientation (left hand shown)
- Installs into current 030-0850 cut-outs

NOTE: Meets FMVSS 206 load requirements and may be used in FMVSS 206 applications pending approval.

Patent Pending

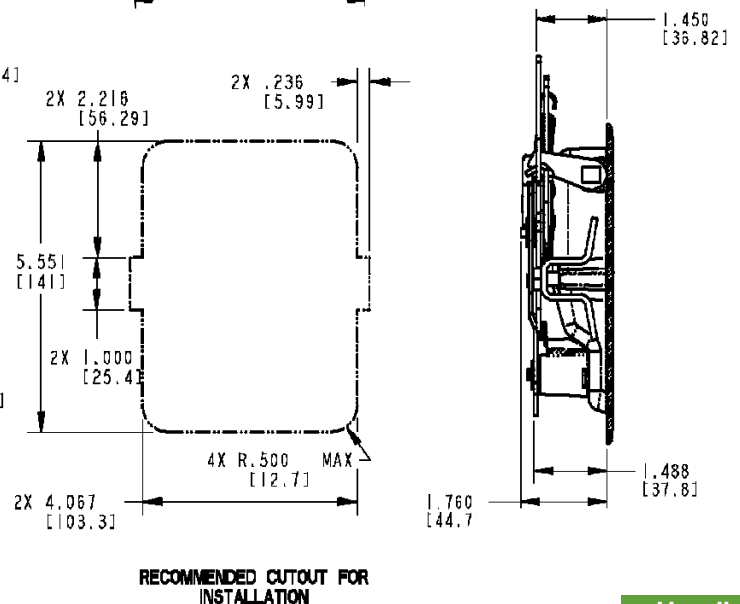
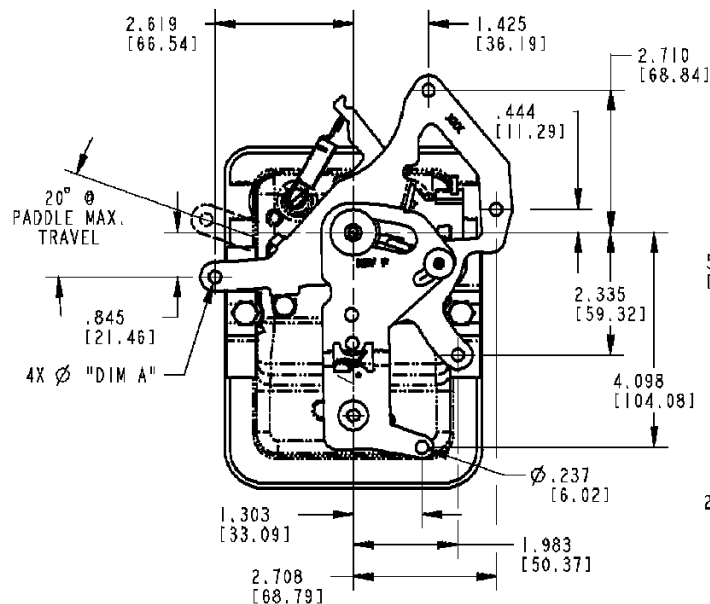
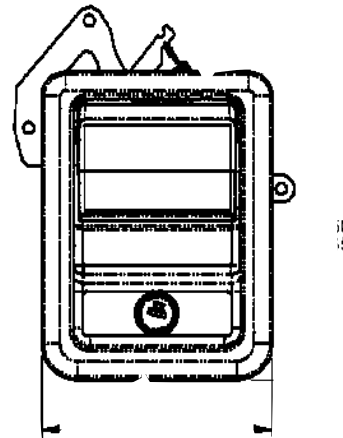

030-0900 Motor Home Entrance Door Hardware With Deadbolt

Designed for motor home entrance doors, this product provides easy installation with through sandwich mounting. It features a large exterior paddle and an ergonomic "L" inside release and is adaptable for power locking.

- Motor home entrance doors with thickness of 1-1/2" (38.1mm) or 1-15/16" (49.2mm)
- Applications requiring resistance to water and dirt infiltration
- Door seal pressures of 25 lbs. (11 kg) or less for ease of function and maximum life (not to exceed 50 lbs [23 kg])
- Right hand applications
- Door weights up to 75 lbs. (34 kg)

FEATURES/BENEFITS:

- Automotive style latch mechanism
- Smooth opening/closing action
- Paddle can be locked before door is shut
- Paddle is rigid when locked
- Comfortable finger access
- New inside handle design facilitates ergonomic function and modern styling
- Adaptable for power door lock actuator
- Built-in dead bolt eliminates the need for an add-on residential type dead bolt
- Dead bolt locks into the fully extended position for true dead bolt functioning

AVAILABLE:

- Master keyed passage lock key cylinder
- Non-master keyed dead bolt
- Gasket (not included)
- Standard or extended length deadbolt
- Sandwich mounting is available for door thicknesses of 1.500 (38.1mm), 1.614 (41.0mm) or 1.875 (47.6mm)

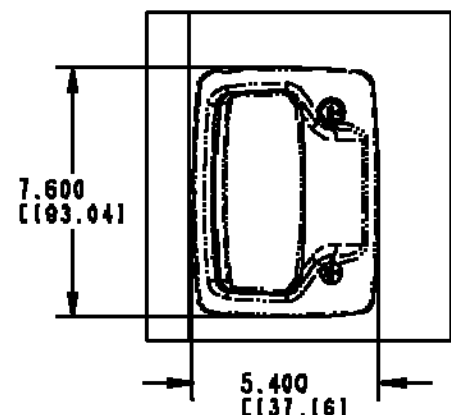
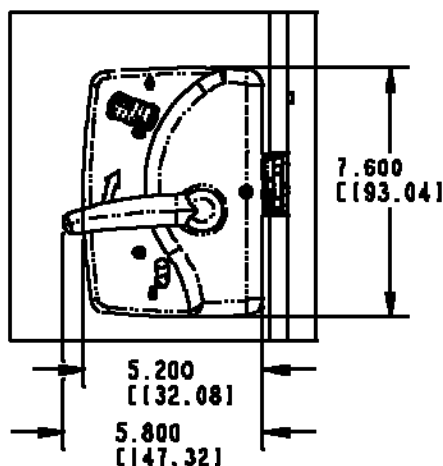
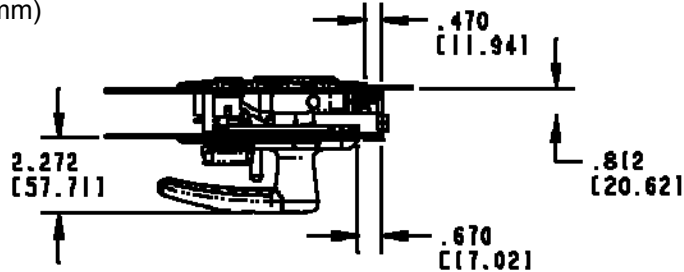

FINISH:

- Black powder coated
- Chrome plated
- Interior release: black powder coat, or white

MATERIAL:

- Housing, inside plates, paddles, and certain lock actuating components: die cast zinc alloy
- Internal latch components: heat treated, smooth edge stamped steel
- Springs: non-corrosive stainless steel
- Case halves: high strength steel

INSTALLATION:

- #8-32 UNC mounting screws (not included). Recommended torque 13 in/lbs (1.4 N-m)
- Sandwich mount installation does not require any linkage rods

NOTE: Meets FMVSS 206 load requirements and may be used in FMVSS 206 applications pending approval.

Design Patent: D529,367

For more information visit
www.trimarkcorp.com

Handles:
Paddle

56

030-1000 / 030-1050 Motor Home Entrance Door Hardware

Designed for motor home entrance doors, this product provides easy installation with a through sandwich mounting. It features a reliable direct release rotary latch and is compliant to FMVSS 206. The 030-1050 includes a built-in dead bolt for additional security.

- Motor home entrance doors with thickness of 1.390" to 1.600". (Different inside plates are required to facilitate range of door thicknesses. Please identify when inquiring.)
- Fifth-wheel trailers, pull-type trailers and slide-in campers
- Applications requiring resistance to water and dirt infiltration
- Door seal pressures of 25 lbs. or less for ease of function and maximum life
- Right hand door applications

FEATURES/BENEFITS:

- Paddle can be locked before door is shut
- Paddle is rigid when locked
- Automotive styling
- Comfortable finger access
- Inside assist for easy closing
- Serviceable shuttered key cylinder
- Built-in dead bolt eliminates the need for an add-on residential type dead bolt
- Dead bolt locks into the fully extended position for true dead bolt functioning (030-1050)

AVAILABLE:

- With optional built-in dead bolt (030-1050)
- Master keyed paddle keycylinder. Non-master keyed dead bolt



MATERIAL:

- Housing, inside plates, paddles, and certain lock actuating components: die cast zinc alloy

FINISH:

- Black powder coated
- Copper-nickel-chrome
- White powder coated

INSTALLATION

- #10-24 thread forming mounting fasteners (not included). Recommended torque 40-50 in-lbs
- Supplied with gasket already applied under recess in housing flange for simple, clean installation
- Sandwich mount installation does not require any linkage rods

NOTE: Meets FMVSS 206 load requirements and may be used in FMVSS 206 applications pending TriMark application approval.

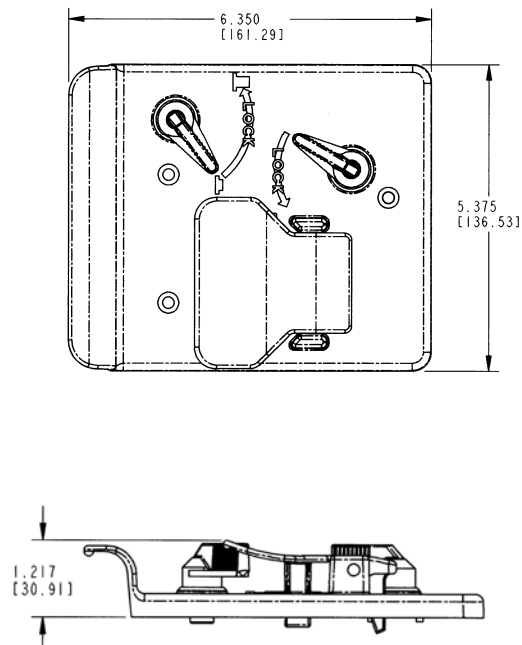
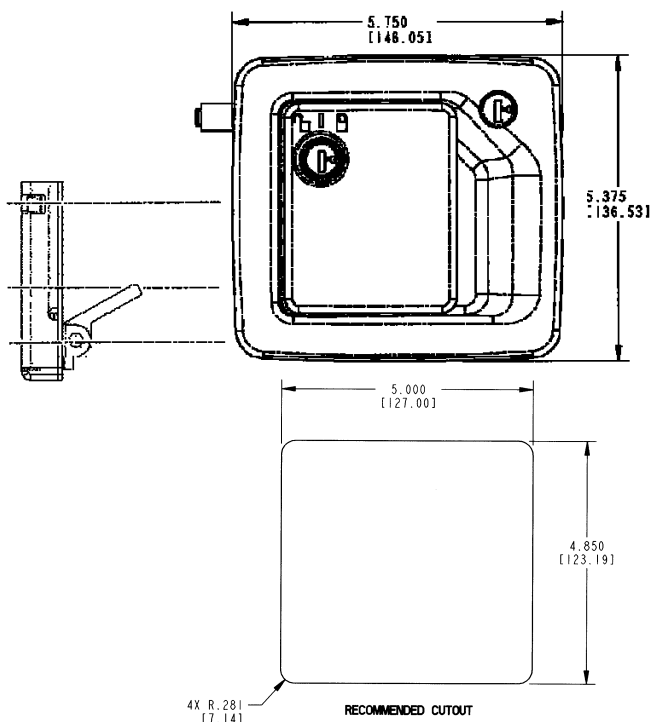

030-1100 Two-Point Paddle Handle

This compartment latch was designed for light to medium duty storage and compartment doors. This non-handed product features a 2-point bellcrank for remote actuation.

- Cross bed tool boxes
- Truck topper and lift gate doors
- Most storage, compartment, and access doors with single or 2-point latch mechanism

FEATURES/BENEFITS:

- Water resistant
- Sleek automotive styling
- Paddle is rigid when locked
- Single point or two-point actuation
- Flush mount -- contoured surface
- Corrosion resistant
- Non-handed design

AVAILABLE:

- Non-locking or locking with shuttered keyway
- 2-point actuation
- Keyed alike
- Keyed random. 50 key codes -- TM901 -TM950
- With rod collars

FINISH:

- Black powder coated



MATERIAL:

- Housing and paddle: die cast zinc alloy
- All steel parts (axles, pivot arm, pivot plate, lock cam): zinc plate clear chromate for corrosion resistance

INSTALLATION:

- Supplied with gasket already applied under recess in housing flange for simple, clean installation
- Single point #10-24 UNC mounting fastener
- Optional mounting brackets (please inquire)

NOTE: Rod collars are not intended or recommended for use in applications that require FMVSS 206 compliance or applications that have heavy or extreme Striker Bolt Loads (> 25 lbs. / 11 kg.) and/or high to extreme usage (> 100,000 door cycles/life).

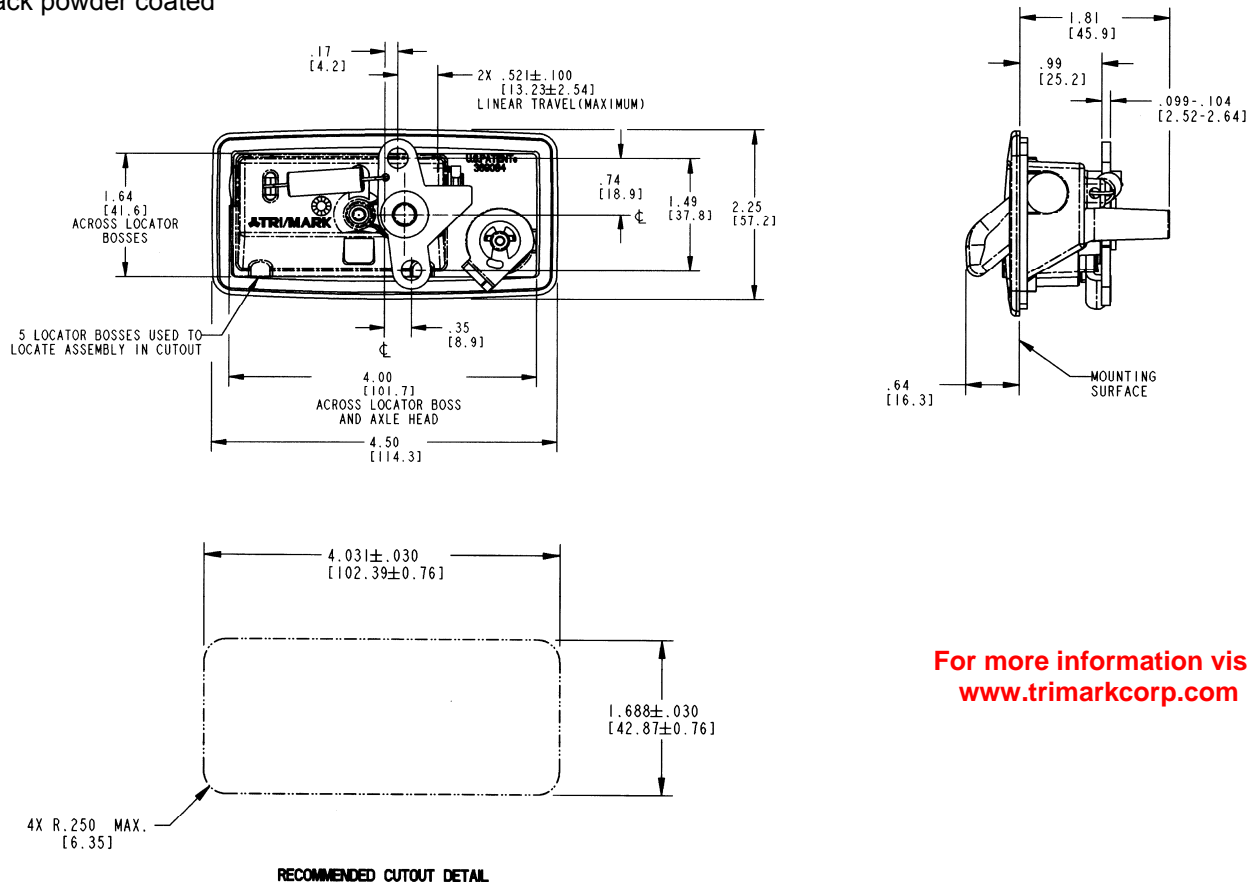

For more information visit
www.trimarkcorp.com

Handles:
Paddle

58

TriMark
www.trimarkcorp.com

030-1125 Paddle Handle With Hook

This compartment latch was designed for light to medium duty storage and compartment doors. This non-handed product features a pivoting hook latching design.

- Cross bed tool boxes
- Truck topper and lift gate doors
- Most storage, compartment, and access doors with single or 2-point latch system

FEATURES/BENEFITS:

- Water resistant
- Sleek automotive styling
- Paddle is rigid when locked
- Shuttered key cylinder
- Keying security
- Flush mount -- contoured surface
- Corrosion resistant
- Slam action -- hook operates independent of paddle

AVAILABLE:

- Non-locking or locking with shuttered keyway
- Keyed alike or keyed random. 50 key codes -TM901-TM950
- Slam action version
- With rod collars



MATERIAL:

- Housing and paddle: die cast zinc alloy
- All steel parts (axles, pivot arm, pivot plate, lock cam): cold rolled steel with zinc plate clear chromate for corrosion resistance

FINISH:

- Black powder coated

INSTALLATION:

- Supplied with gasket already applied under recess in housing flange for simple, clean installation
- Blind mounting with one #10-24 UNC mounting fastener
- Optional mounting brackets (please inquire)
- Optional hook designs (13980-01 please inquire)

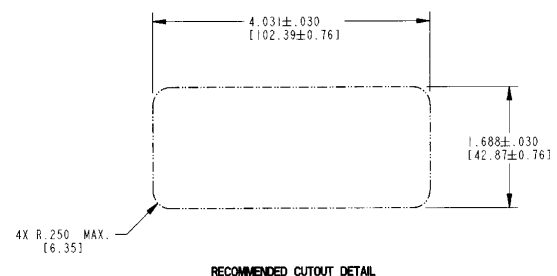
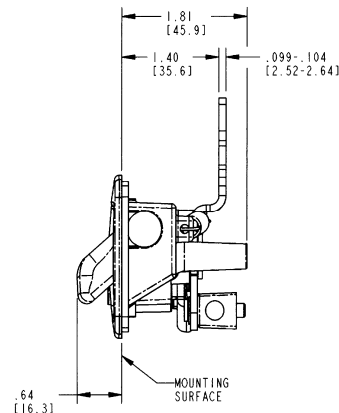
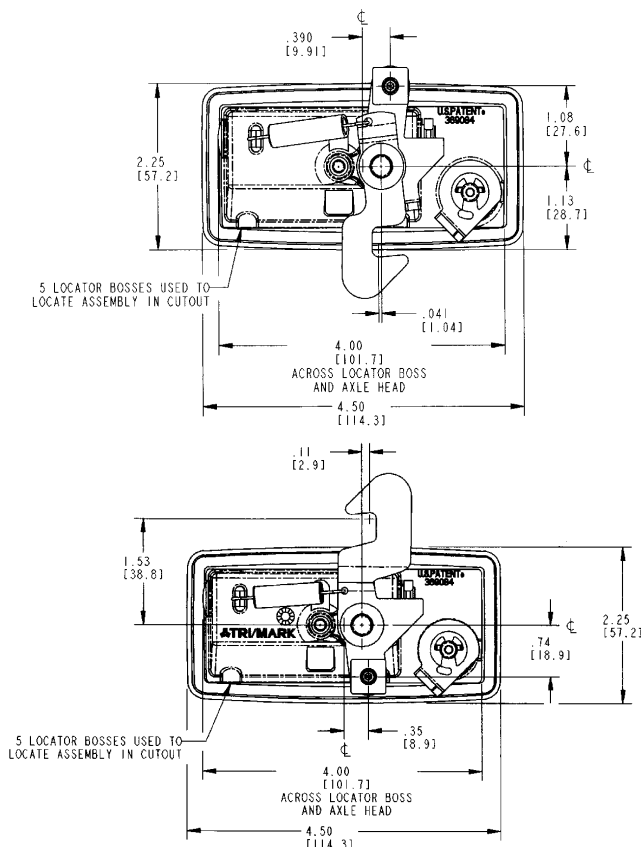

030-1200 Round Paddle Handle

The 030-1200 Round Paddle Handle was designed for use on personnel and compartment doors for light to medium duty for on or off-highway applications. This ergonomic handle offers compact size for a cost effective price and brings a modern look and function to your cabs and enclosures.

- Light to medium duty agricultural and construction personnel and compartment doors
- Any baggage or compartment door for on or off-highway applications
- Use in a direct latch release application or used in conjunction with a bellcrank for single point remote actuation

FEATURES/BENEFITS:

- Ergonomic function and styling
- Interior or exterior applications
- Rigid handle when locked
- Lock can be keyed to match other TriMark door products with KeyOne™ Plus for a single-key system, keyed alike or provided non-locking
- Non-handed configuration allows for universal applications

AVAILABLE:

- With a conventional paddle or open bail style handle for maximum leverage
- Can be keyed alike with most single and reversible key systems
- In locking or non-locking configurations
- With gasket for maximum water resistance
- With standard mounting bracket

For more information visit
www.trimarkcorp.com

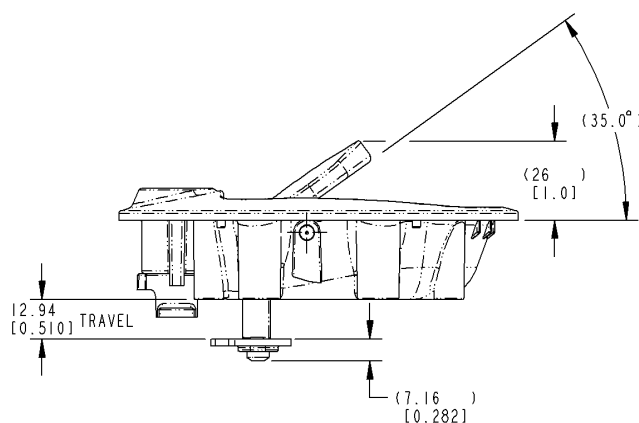

MATERIAL:

- Handle, paddle and actuator: engineered plastic withstands corrosion and UV exposure
- Spring: non-corrosive stainless steel

INSTALLATION:

- Easy installation with (4) M6 special high performance thread forming fasteners available
- Allows for glass mounting through a single 120mm diameter hole or steel through a double-D cutout

NOTE: Product does not meet the locking requirements for FMVSS 206

U.S. Patent No. 7,611,173

Design Patent No. D541,129

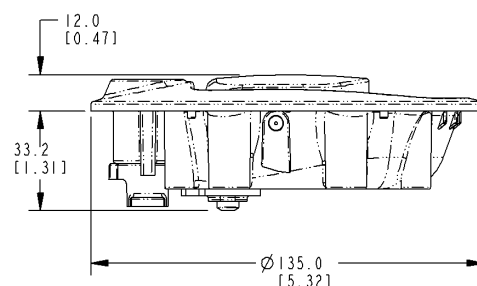
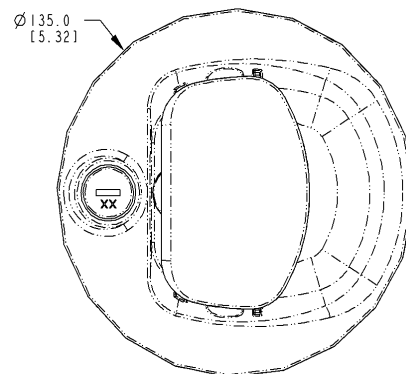

Handles:
Paddle

60

TriMark
www.trimarkcorp.com

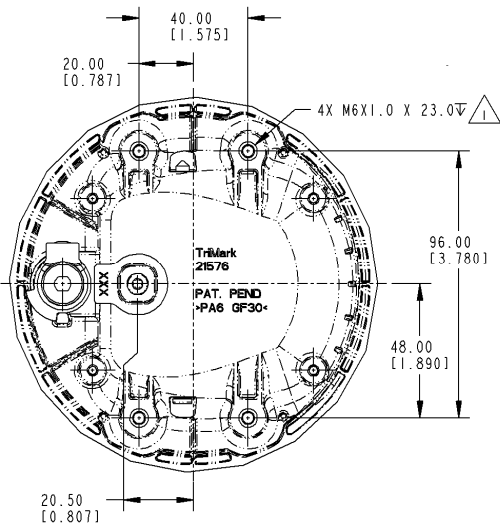

NOTE: UNLESS OTHERWISE SPECIFIED;

△ RECOMMENDED INSTALLATION TORQUE TO BE 9.4-11.5 N-m [83-102 lbf-in]

For more information visit www.trimarkcorp.com

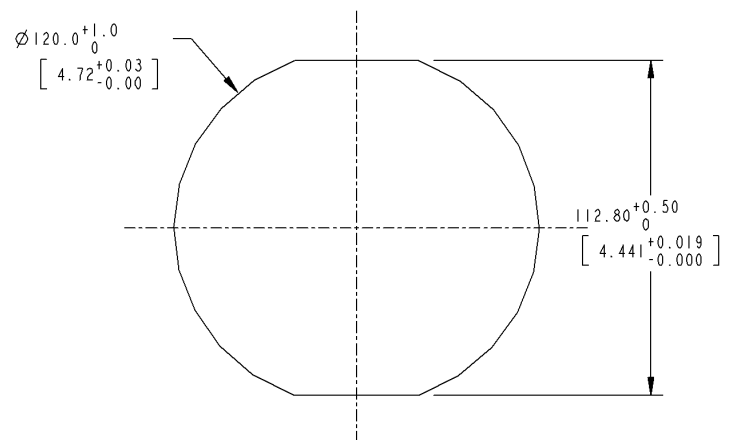
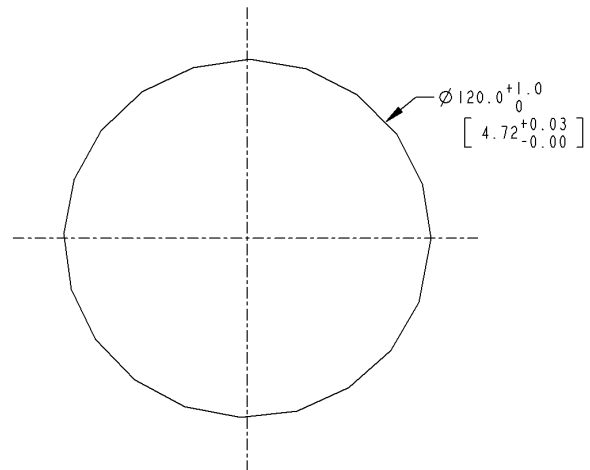
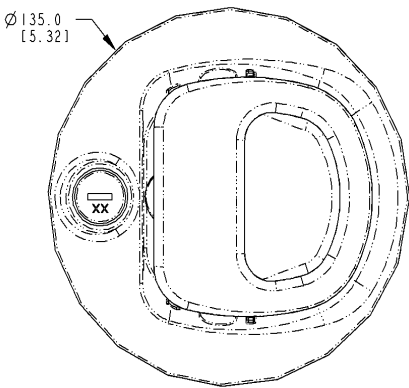

030-1300 D-Paddle Handle

This compartment paddle handle is designed for utility and service bodies, emergency vehicles and baggage doors for recreational vehicles. It features a multipoint bellcrank and is available in black or buffed copper-nickel-chrome finishes.

AVAILABLE:

- In locking or non-locking configurations
- With single rotor latch module (050-0206) that can be orientated at 90° intervals with the paddle depending on application
- With gasket for flange of housing to provide resistance to water and dirt infiltration
- Multiple pivot plate for doors that require a remote latching mechanism

MATERIAL:

- Housing and paddle: die cast zinc alloy
- Internal latch components: case hardened, smooth edge stamped steel
- Springs: stainless steel, non-corrosive
- Other components: zinc plate mild steel

FINISH:

- Housing and paddle: black powder coated or buffed copper-nickel-chrome plated
- Stampings: zinc plate clear chromate conversion coat



INSTALLATION:

- Easy drop-in installation
- Integrated rotary: mounts with (2) 1/4-20 UNC threaded cutting screws (not included)
- Two-point: mounts with (4) #10-24 UNC screws (not included)
- Retrofits with most folding D-ring handles presently used

CAUTION: Compartment latch does not meet FMVSS 206 requirements.

Design Patent No. 390,443

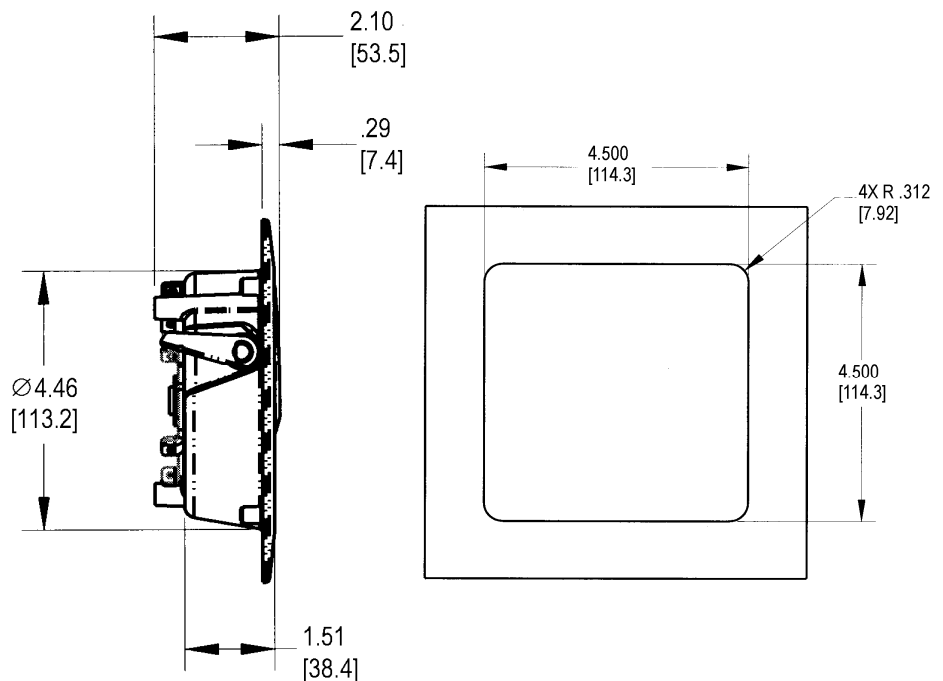
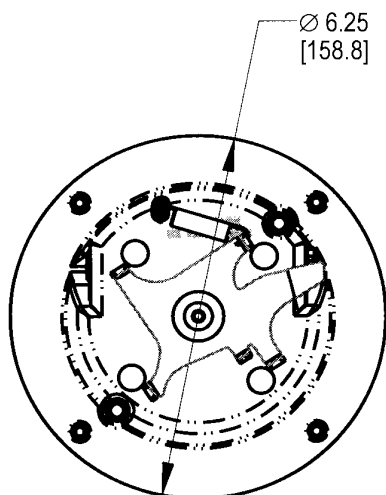

030-1400 Paddle Handle

This flush mounted paddle is a redesign of our 030-0400 paddle handle for entrance doors on RV and specialty vehicles. Containing the same proven mechanical details as previous with a modernized look, it can be used in FMVSS 206 applications and features a remote pivot plate and lock cam actuation.

AVAILABLE:

- Lock can be keyed to match other TriMark door products with KeyOne™ Plus for a single-key system, keyed alike or provided non-locking
- Several pivot plate options are available to suit a wide variety of applications



MATERIAL:

- Sturdy zinc die cast alloy housing and paddle
- Steel components: zinc plated, mild steel



FINISH:

- Standard black powder coated, buffed copper-nickel-nickel-chrome plated or combination black powder coated housing and buffed chrome paddle

INSTALLATION:

- Handle is easy to install with supplied single 1/4-20 UNC nut and mounting bracket (mounting torque not to exceed 30 in-lbs [3.39N-m])
- Either handed version can be installed in a wide range of locations in both horizontal or vertical orientations (left hand shown)
- Retrofits with most 030-0400 flush paddle handles

NOTE: Meets FMVSS 206 locking requirements and may be used in FMVSS 206 applications pending TriMark application approval.

U.S. Patent No. 5,606,882
Design Patent No. D537,701

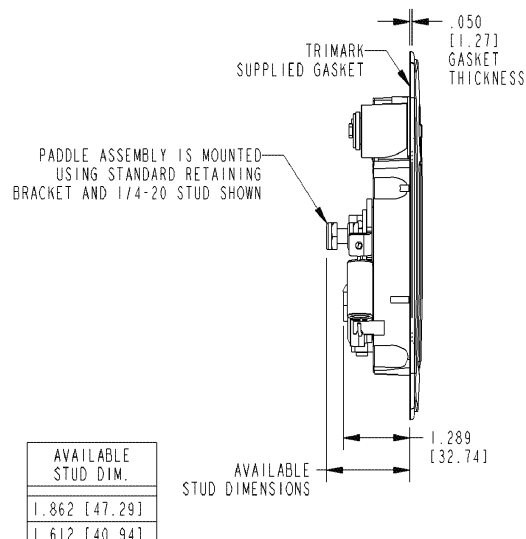
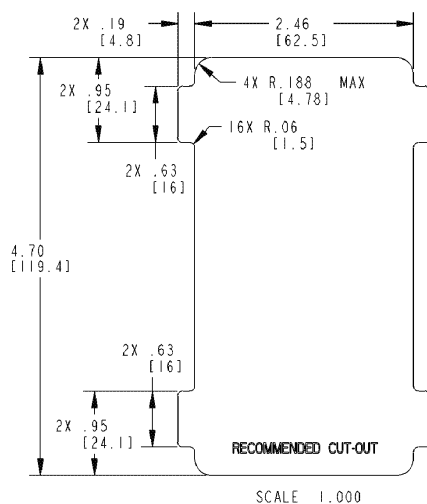
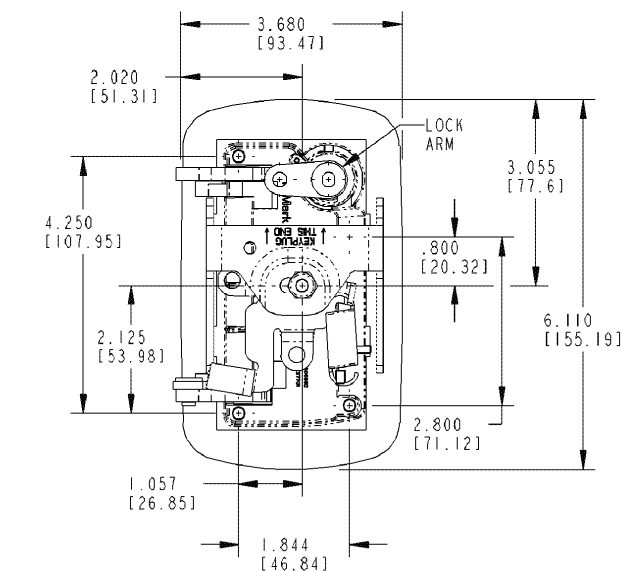

AVAILABLE STUD DIM.
1.862 [47.29]
1.612 [40.94]

030-1425 Paddle Handle

This redesigned product functions as a remote inside release and features a built-in lock lever and improved zinc die cast bezel for durability and ease of installation. It is also available in non-locking and power locking versions.

- Remote interior release and locking applications for on or off-highway
- Light to medium duty recommended
- Use with TriMark latch/logic mechanisms

FEATURES/BENEFITS:

- Offers modern automotive styling
- Built-in lock lever for added security
- Remote mounting provides versatility and flexibility

AVAILABLE:

- Right or left hand configurations (right hand shown)
- Cutout for power door lock
- Non-locking bezel also available
- As a complete assembly or separate components for application flexibility



MATERIAL:

- Bezel and release lever die cast zinc alloy
- Lock lever -- engineered plastic
- Stamped steel mounting brackets

INSTALLATION:

- Fasteners supplied for mounting inside bezel

NOTE: Meets FMVSS 206 load requirements and may be used in FMVSS 206 application pending TriMark application approval.

**Design Patent No. D589,729
D588,895**

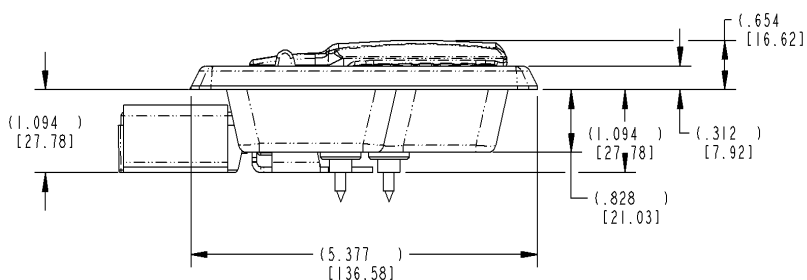
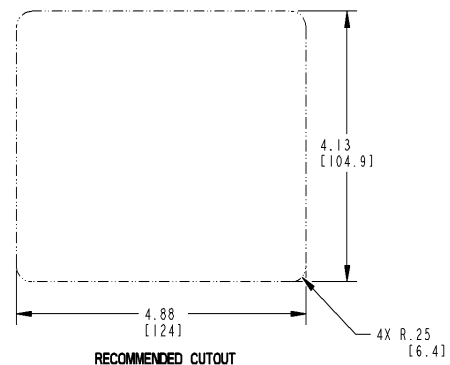
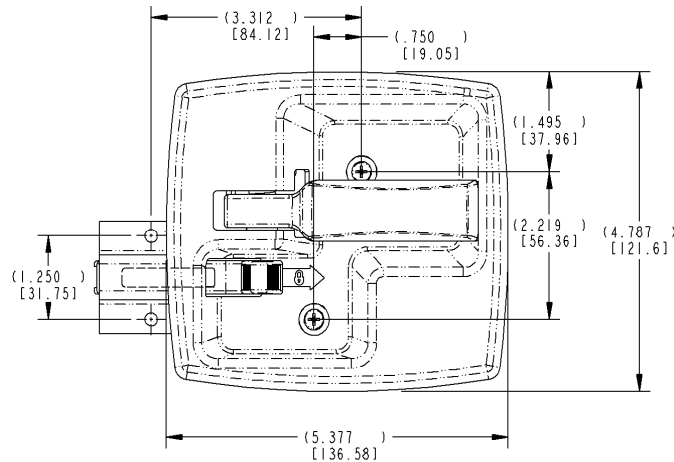

For more information visit
www.trimarkcorp.com

030-1450 2-Point Paddle Handle

This flush mounted paddle is a redesign of our 030-0450 paddle handle for compartment doors and entrance doors on RV and specialty vehicles. Containing the same proven mechanical details as previous with a modernized look, it can be used in FMVSS 206 applications, is power lockable and features 2-point remote pivot plate and lock cam actuation.



FEATURES/BENEFITS:

- Offers updated styling
- Paddle is rigid when locked
- Inside lock detail provides for multiple connection points for use of inside lock and/or powerlock actuation
- Molded rubber gasket for flange of housing provides resistance to water and dust infiltration

AVAILABLE:

- Lock can be keyed to match other TriMark door products with KeyOne™ Plus for a single-key system, keyed alike or provided non-locking
- Several 2-point pivot plate options are available to suit



INSTALLATION:

- Handle is easy to install with single 1/4-20 UNC nut and supplied mounting bracket (Mounting torque not to exceed 30 in-lbs [3.39N-m])
- Either handed version can be installed in a wide range of locations in either horizontal or vertical orientations (left hand shown)
- Retrofits with most 030-0450 flush paddle handles

FINISH:

- Standard black powder coated, buffed copper-nickel-nickel-chrome plated or combination black powder coated housing and buffed chrome paddle

MATERIAL:

- Sturdy zinc die cast alloy housing and paddle
- Steel components: zinc plated, mild steel

NOTE: Meets FMVSS 206 locking requirements and may be used in FMVSS 206 applications pending TriMark application approval.

Design Patent No. D537,701

For more information visit
www.trimarkcorp.com

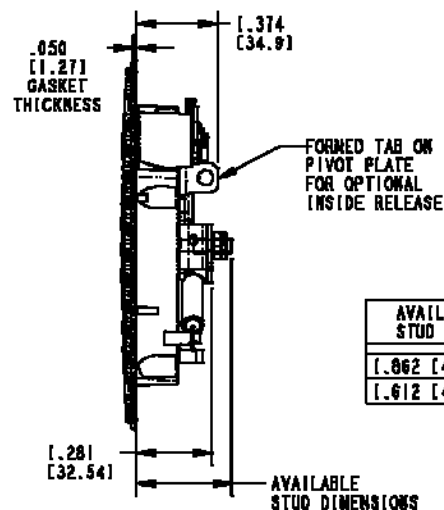
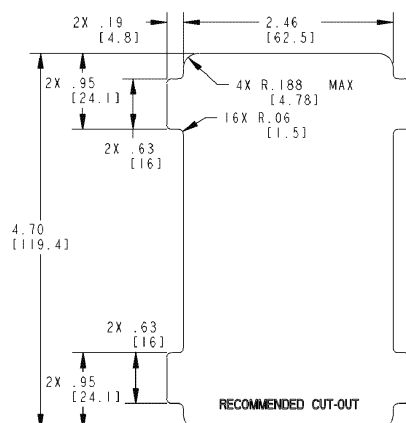
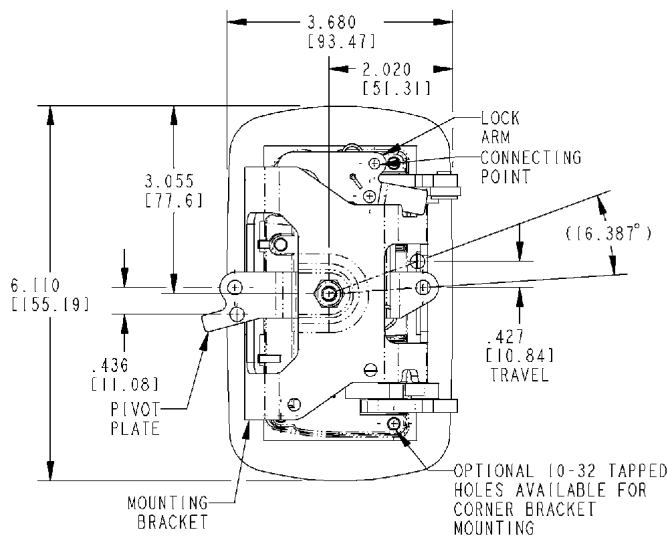

AVAILABLE STUD DIM.
1.862 [47.20]
1.612 [40.94]

MOUNTING BRACKET NOT SHOWN
TriMark
www.trimarkcorp.com

Handles:
Paddle

65

030-2000 Two-Point Free Float Baggage Lock

Designed for recreational vehicle baggage doors, this product is available in black or copper-nickel-chrome plated finish and features a two-point bellcrank for remote actuation and is power lockable.

- Two-point assembly ideally suited to fit 1.25" (31.8mm) and thicker foam core doors with linkage release efforts up to 7 lbs (3.2 kg) per linkage rod

FEATURES/BENEFITS:

- Foam gasket on flange of housing provides resistance to water infiltration
- Paddle free-floats when locked
- Modern automotive styling
- Adaptable to powerlock actuation
- Paddle can be locked before door is shut
- Large handle provides comfortable finger access and greater ease of operation (ergonomics)

AVAILABLE:

- Handle can be keyed to match other TriMark RV door products with KeyOne™ Plus for a single-key system, keyed alike or provided non-locking
- Linkage rods available for your specific applications
- In right or left hand configurations (right hand shown)



MATERIAL:

- Sturdy zinc die cast alloy paddle and housing
- All steel parts (axles, pivot arm, pivot plate, lock cam): cold rolled steel with zinc plate clear chromate for corrosion resistance

FINISH:

- Supplied black powder coated, this product can easily be painted over to match body colors
- Also available copper-nickel chrome plated

INSTALLATION:

- Easy drop-in installation
- Supplied with gasket already applied under recess in housing flange for simple, clean installation
- Mounts with (3) 1/4-20 UNC thread forming screws (not supplied)
- Optional mounting bracket and rod designed for easy installation of power actuation
- Either handed version can be installed in a wide range of locations in door — horizontal or vertical orientation

U.S. Patent No. 6,708,537

Design Patent No. D496,576

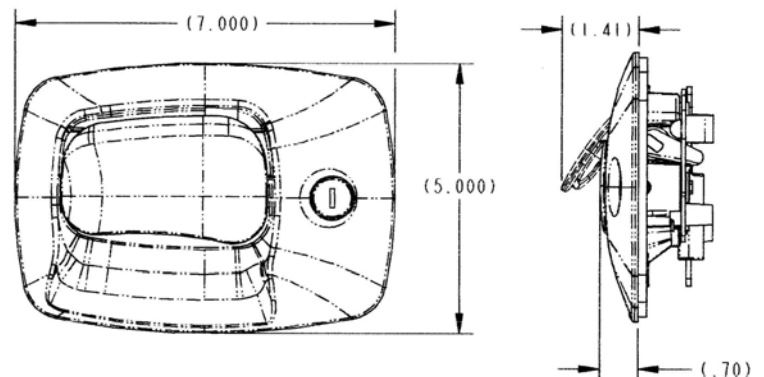
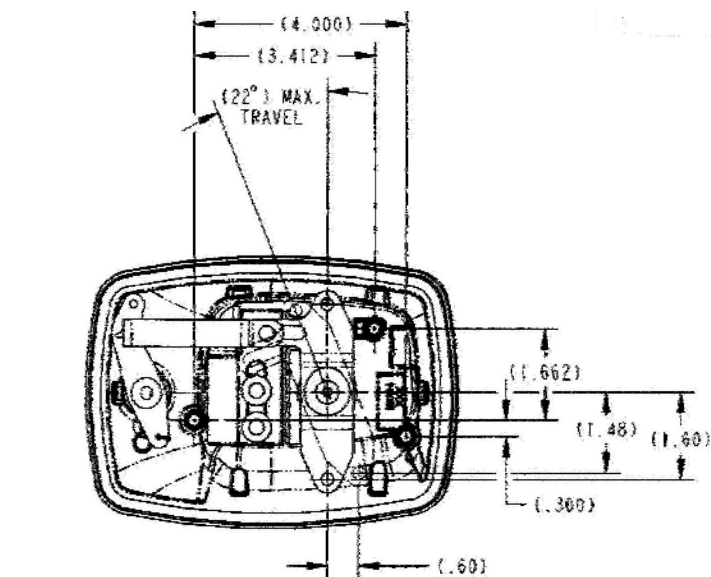
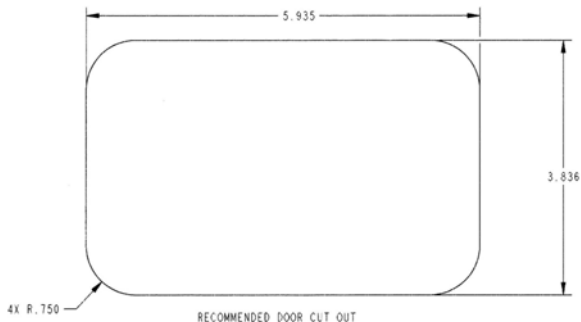

For more information visit
www.trimarkcorp.com

Handles:
Paddle

66

TriMark
www.trimarkcorp.com

030-2300 Wedge Paddle Handle

This flush mounted paddle handle is designed specifically for medium to heavy-duty off-highway vehicle entrance doors that require remote actuation. It is retrofittable with similar excavator paddle handles and offers robust construction for a very cost effective price.

FEATURES/BENEFITS:

- Off-highway construction equipment applications
- Doors requiring latch location remote from actuating handle
- Door thickness of 55mm or greater
- Comfortable finger access
- Adaptable for power door lock actuation
- Molded gasket for flange of housing provides resistance to water infiltration



AVAILABLE:

- Lock can be keyed to match other TriMark door products with KeyOne™ Plus for a single-key system, keyed alike or provided non-locking
- Choice of locking functions; locked rigid within the paddle or remote free-float locking to connect with latch/linkage



INSTALLATION:

- Easy to install with (3) M5 mounting screws (not included)
- Recommended mounting torque 3.4 N-m

MATERIAL:

- Sturdy die cast zinc alloy paddle and housing
- Pivot plate, lock cam and paddle axle: mild steel

FINISH:

- Black powder coated housing and paddle
- Zinc plated clear chromate steel components

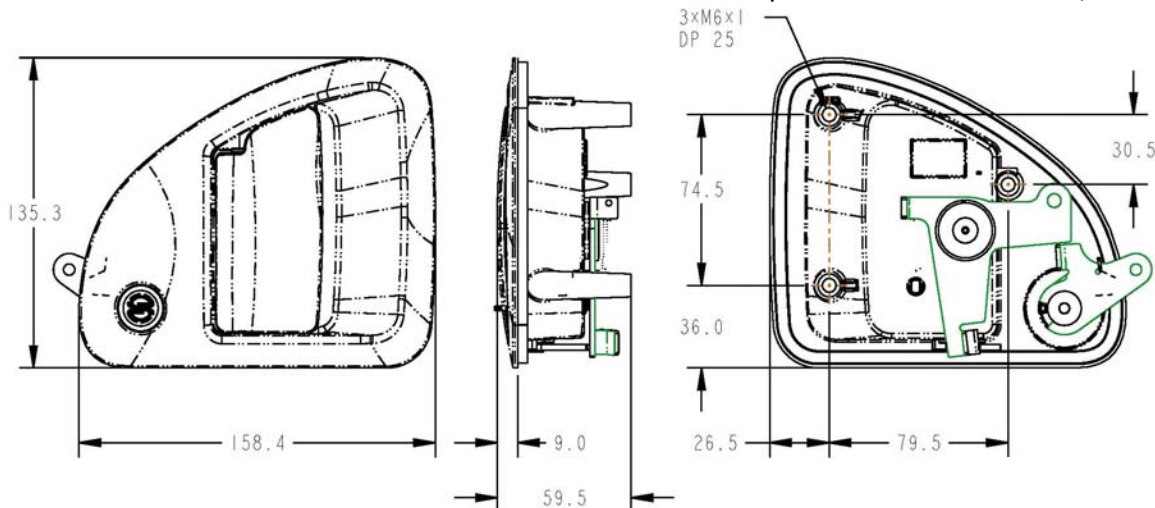
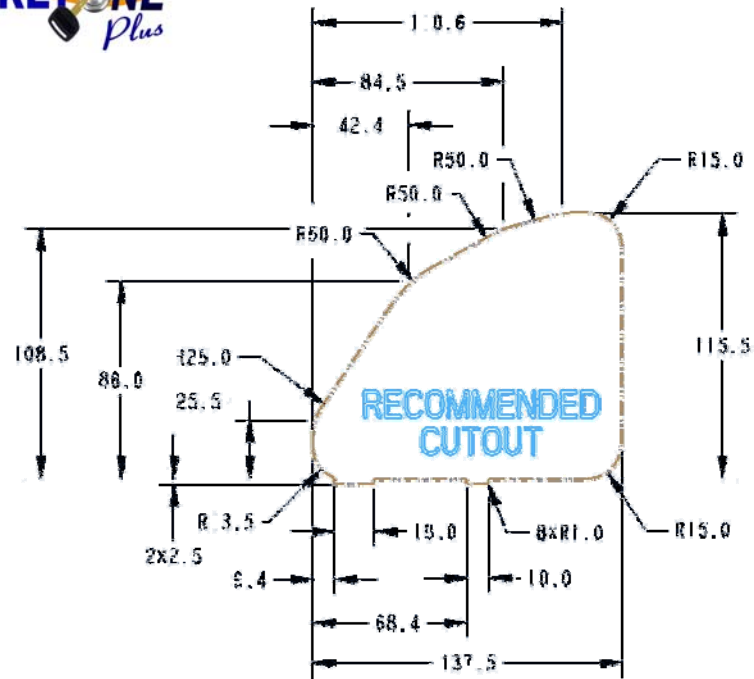

060-0201 / 060-0251 Trailer Latch

This trailer latch was specifically designed for entrance, baggage and compartment doors for recreational vehicles including motor homes and travel trailers. It features a modern styled paddle and provides a single reversible key system with TriMark's KeyOne™ Plus system.

- All doors with thickness of 1-1/4" (31.8mm) to 1-1/2" (38.1mm) (other door thicknesses available -- please inquire)
- Universal applications--either right or left handed

FEATURES/BENEFITS:

- Paddle can be locked before door is shut
- Paddle is rigid when locked
- Automotive styling
- Comfortable finger access
- Inside assist for easy door closing
- Water resistant
- Master keying is standard for paddle key cylinder

AVAILABLE:

- With optional built-in dead bolt (060-0251 Series)
- Reversible key for ease of operation
- With or without inside release (060-0201 Series)
- Reverse plunger for inward swinging doors (optional)
- Lock can be keyed to match other TriMark door products with KeyOne™ Plus for a single-key system, keyed alike or provided non-locking



MATERIAL:

- Major components: die cast zinc alloy
- Strike plate (standard version): die cast zinc alloy
- Strike plate (optional dead bolt version): steel or non-corrosive stainless steel
- Non-metallic plunger

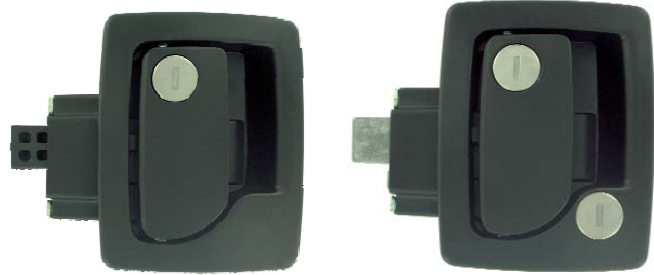

060-0251 Trailer Latch

060-0251 Trailer Latch
With Dead Bolt

FINISH:

- Black powder coated or white
- Copper-nickel chrome plated
- Strike plate (standard version): black powder coating
- Strike plate (optional deadbolt version): zinc plated

INSTALLATION:

- Requires (4) #8-32 thread forming fasteners (Available --please inquire)

060-0251 Series Dead Bolt Features

- Built-in dead bolt eliminates the need for an add-on residential type dead bolt
- Requires the same cut-out detail as the standard latch assembly (060-0200/0250/0201)
- Same fasteners may be used for all versions
- Dead bolt locks into the fully extended position for true dead bolt functioning
- Master keying is standard for paddle key cylinder

CAUTION: Latch does not meet FMVSS 206 load requirements

U.S. Patent No. 6,409,234

5,927,773

Design Patent No. D419,421

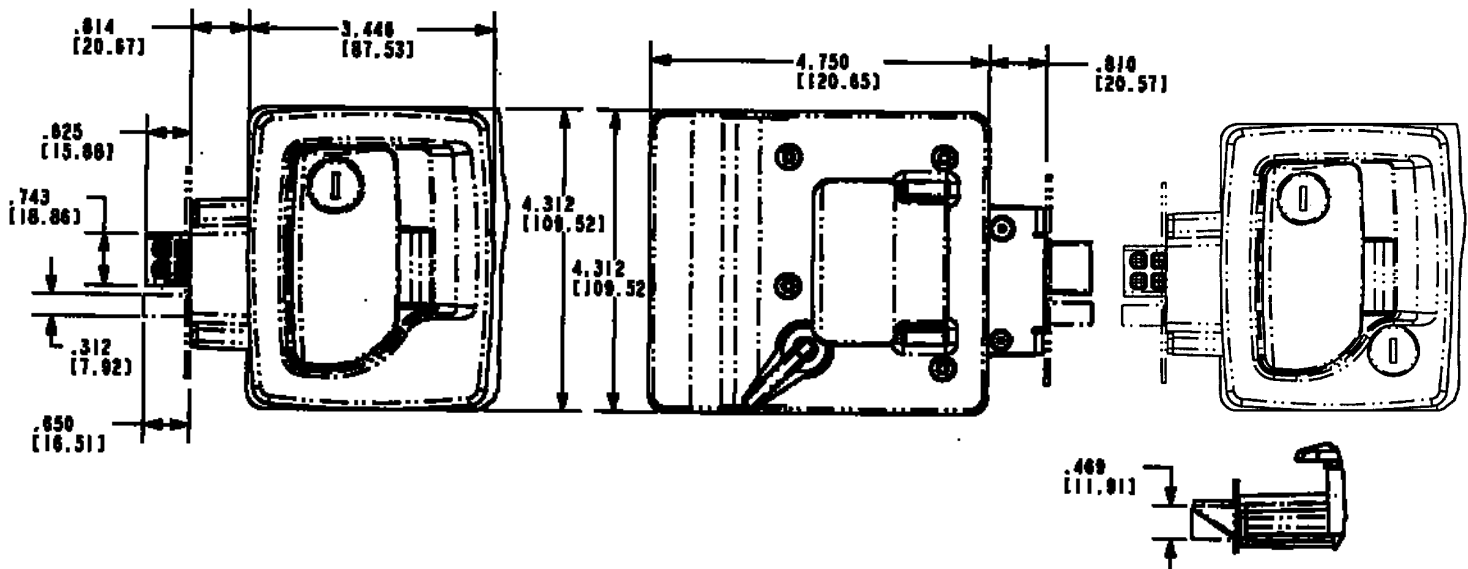

060-0460 EZ Access Baggage Door Lock

This door lock was specifically designed for baggage and compartment doors for recreational vehicles including motor homes and travel trailers. It features a modern styled paddle and is available with multi-point functionality or as a single point.

FEATURES/BENEFITS:

- Offers lower operating efforts and a more forgiving assembly
- Ample finger clearance
- Paddle can be locked before the door is shut (slam action)
- Updated styling
- Improved plunger design
- Increased mechanical advantage to allow for lower operating efforts
- Available in single or 3-point actuation for latching versatility

AVAILABLE:

- Locking or non-locking
- Keyed alike
- Wide variety of mounting bracket options available for various applications
- Lock can be keyed to match other TriMark door products with KeyOne™ Plus for a single-key system, keyed alike or provided non-locking
- Multi-point actuation or single point
- Zinc or plastic plunger



FINISH:

- Paddle and housing: powder coat in various colors
- Steel components: zinc coat with clear chromate

MATERIAL:

- Housing and paddle: die cast zinc
- Pivot plate, axles, pivot arm: steel
- Plunger bolt: plastic or die cast zinc

INSTALLATION:

- Mounts with four (4) #8-32 thread forming fasteners (not supplied)
- Supplied with gasket already applied under recess in housing flange for simple, clean installation

U.S. Patent No. 6,547,290

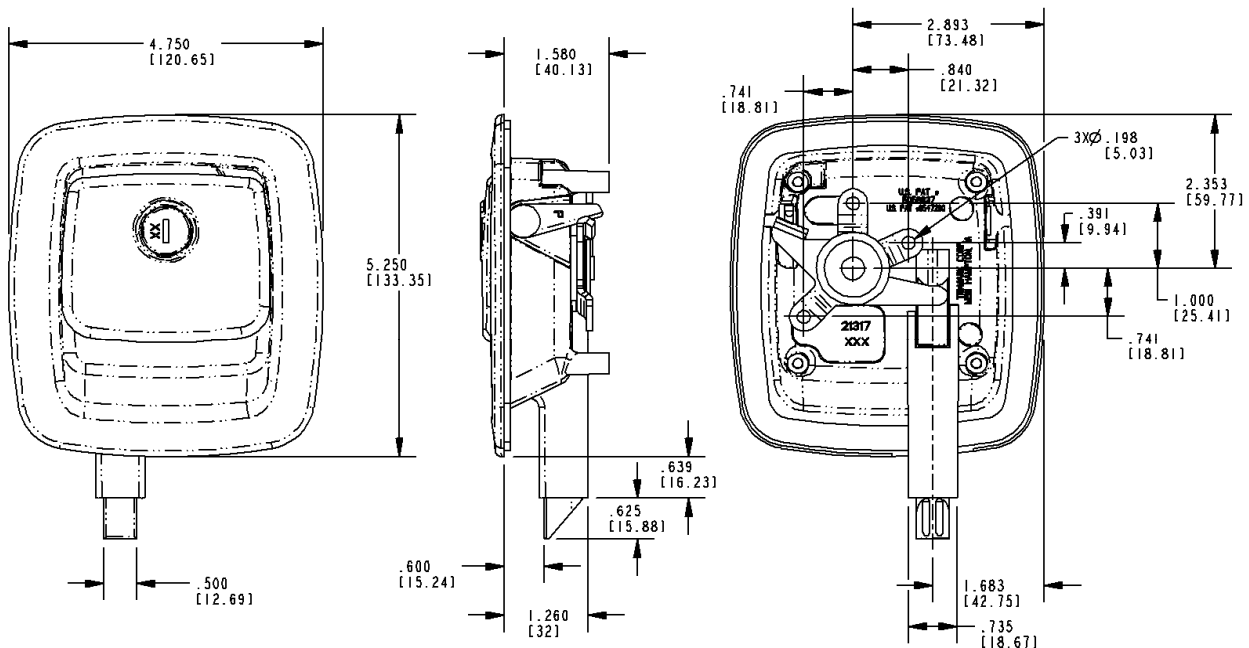

Handles:
Paddle

70

060-0475 Flush Baggage Door e-LOCK

This baggage door lock was specifically designed for baggage and compartment doors for recreational vehicles including motor homes and travel trailers. It features a modern styled paddle and offers the use of power door lock actuation. It is available with multi-point functionality or as a single point with either a zinc or plastic plunger.

FEATURES/BENEFITS:

- Offers modernized styling
- Allows the use of power door lock actuation
- Large handle provides comfortable finger access and greater ease of operation (ergonomics)
- Single point zinc or plastic plunger or multi-point functionality works with TriMark rotary or plunger latches in doors 1.187" (30.1mm) and thicker
- Multi-point handle can be mounted in vertical or horizontal orientations and is able to actuate latches at the sides and also the top and bottom of the door
- Paddle can be locked before the door is closed (slam action)

FINISH:

- Supplied painted in a low gloss black finish, the product can be easily painted over to match body colors
- Also available copper-nickel chrome plated

MATERIAL:

- Sturdy zinc die cast alloy housing, paddle and plunger
- All parts (axles, pivot arm, pivot plate, lock cam): cold rolled steel with zinc plate, clear chromate for corrosion resistance
- Engineering plastic used for plunger bolt drive end and plunger bolt (when specified) has lower coefficient of friction, reducing closing and operating efforts



AVAILABLE:

- With or without plunger bolt for one or multi-point operation
- Single point version is available with a zinc or plastic plunger
- Lock can be keyed to match other TriMark door products with KeyOne™ Plus for a single-key system, keyed alike or provided non-locking
- Housing flange and internal gaskets provided for resistance to water and dirt infiltration
- Linkage rods available for your specific applications



INSTALLATION:

- Handle is easy to install with (3) #8-32 thread forming fasteners (supplied separately)
- Optional mounting bracket and rod allows the power actuator to mount to the handle for ease of installation
- Supplied with gasket already applied under recess in housing flange for simple, clean installation

U.S. Patent No. 7,232,162

Design Patent No. D519,823

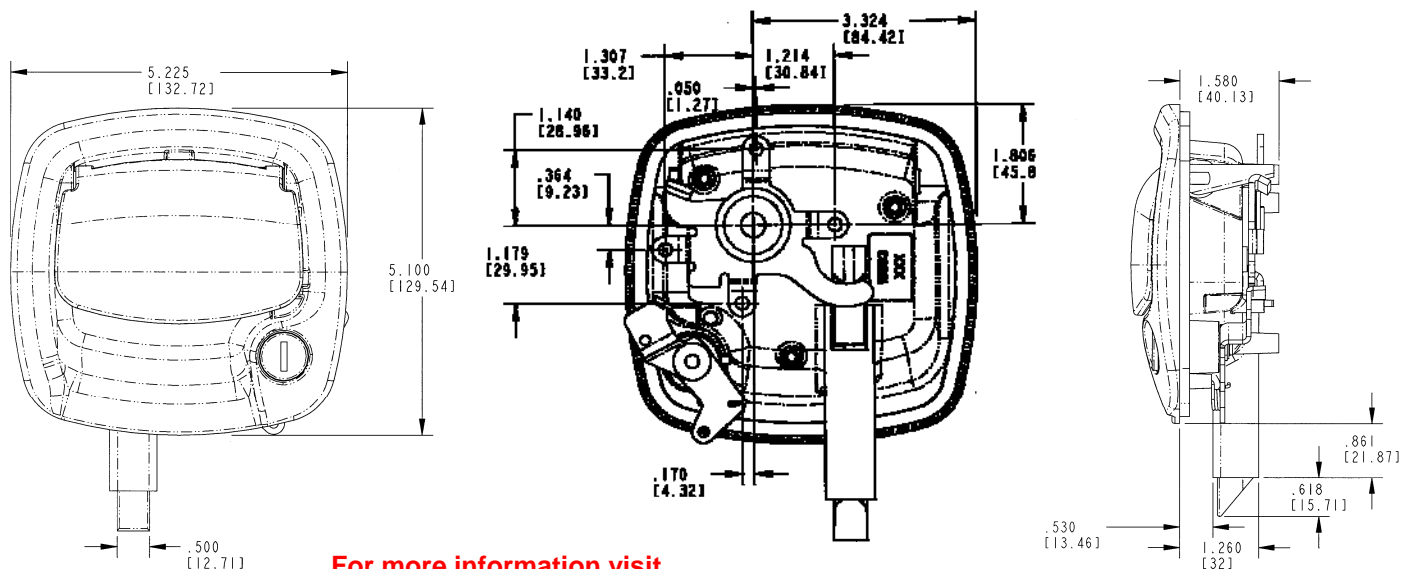

For more information visit
www.trimarkcorp.com

060-0600 / 060-0650 Motor Home Entrance Door Hardware

Designed for motor home entrance doors, this product provides easy installation with a through sandwich mounting. It features a low cost plunger style latch and is compliant to FMVSS 206. The 060-0650 includes a built-in dead bolt for additional security.

- Motor home entrance doors with thickness of 1.390" (35.3mm) to 1.600" (40.6mm). (Different inside plates are required to facilitate range of door thicknesses. Please identify when inquiring.)
- Universal applications--either right or left handed

FEATURES/BENEFITS:

- Paddle can be locked before door is shut
- Paddle is rigid when locked
- Automotive styling
- Comfortable finger access
- Inside assist for easy closing
- Serviceable shuttered key cylinder
- Built-in dead bolt eliminates the need for an add-on residential type dead bolt
- Dead bolt locks into the fully extended position for true dead bolt functioning (060-0650)
- Strike plate: heat treated and zinc plated steel

AVAILABLE:

- With optional built-in dead bolt (060-0650)
- Master keyed paddle keycylinder. Non-master keyed dead bolt

FINISH:

- Black powder coated
- Copper-nickel-chrome plated

This product is currently under a redesign and will be replaced within 12 months. For additional information, please contact Customer Service at 1-800-447-0343.

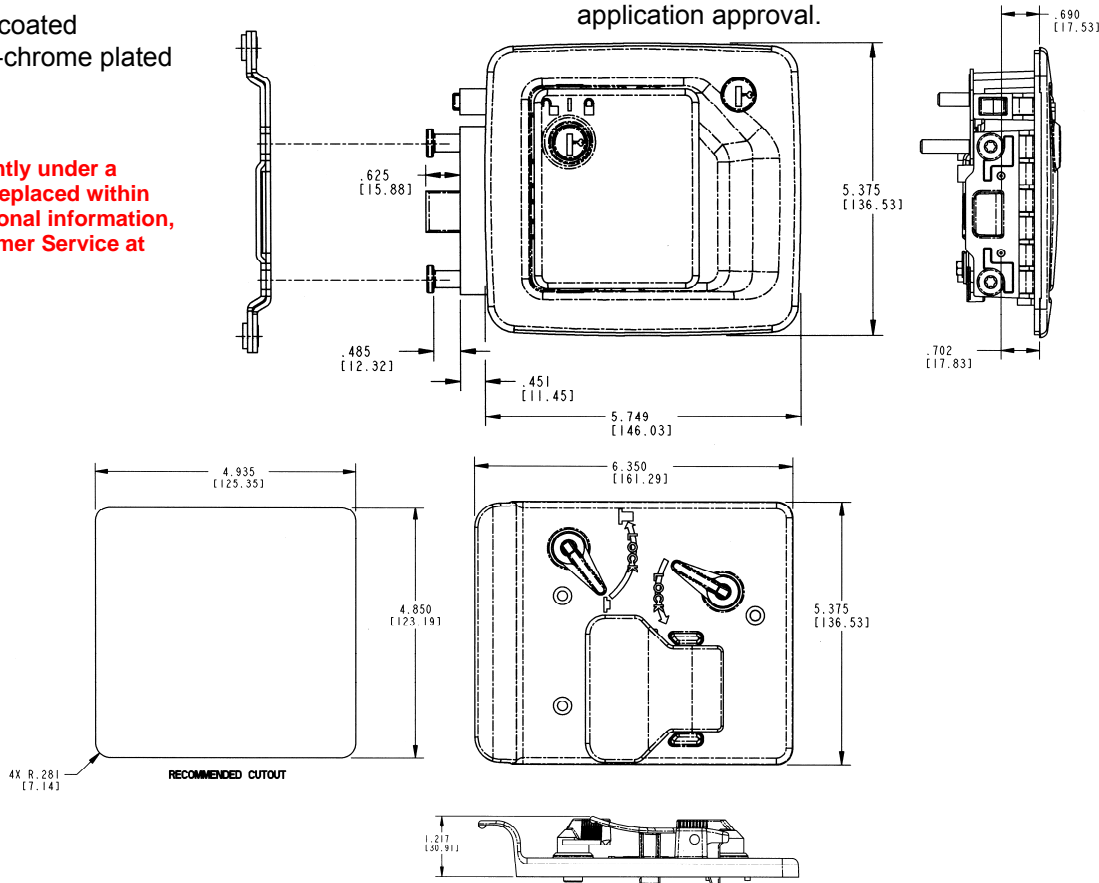

060-0600 Motor Home Entrance Door Hardware



060-0650 Motor Home Entrance Door Hardware With Dead Bolt



MATERIAL:

- Housing, inside plates, paddles, plunger bolt and certain lock actuating components: die cast zinc alloy
- Strike plate: heat treated and zinc plated steel

INSTALLATION:

- #10-24 UNC mounting screws (not included). Recommended torque 10 in./lbs. (1.1 N-m) 1/4-20 UNC grade 5-type fasteners for strike plate installation recommended
- Supplied with gasket already applied under recess in housing flange
- Sandwich mount installation does not require any linkage rods

NOTE: Meets FMVSS 206 load requirements and may be used in FMVSS 206 applications pending TriMark application approval.

Handles:
Paddle

72

020-0700 Flush Pull Handle

This pull handle was specifically designed for compartment and entrance doors for heavy truck, service truck, ambulance, fire/rescue and off-highway vehicles. It offers ergonomic function and styling, is adaptable for power door lock actuation and has a "free-floating" handle when locked.

- Class 7-8 trucks
- Utility bodies
- Off-highway vehicles (light duty)

FEATURES:

- Ergonomic function and styling
- Can be keyed to match common ignition locks (not included - please inquire)
- Paddle is "free-floating" when locked and used with appropriate latch/linking with lock logic
- Adaptable for power door lock actuator
- Interior or exterior applications
- Housing flange and internal gaskets provided for resistance to water and dirt infiltration

MATERIAL:

- Housing: glass reinforced black nylon, brass threaded mounting studs
- Handle: glass reinforced black nylon
- Pivot plate: mild steel



FINISH:

- Black housing, black nylon handle
- Zinc plated clear chromate steel components

AVAILABLE:

- Right and left hand configurations (right hand shown)
- Locking and non-locking

INSTALLATION:

- Easy mounting with (2) M6 nuts
- Recommended mounting fastener torque 30-40 in-lbs (3.3-4.4 N-m)
- Either horizontal or vertical orientation
- Non-handed standard mounting bracket (sold separately)

NOTE: Meets FMVSS 206 locking requirements and may be used in FMVSS 206 applications pending TriMark application approval.

U.S. Patent No. 6,802,544

6,805,388

Design Patent No. D489,957

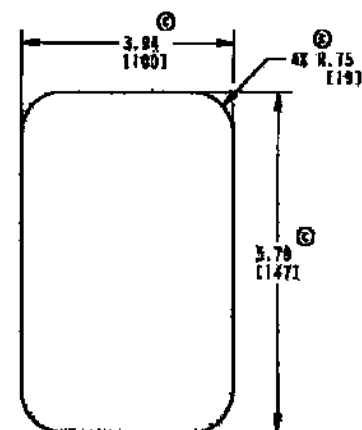
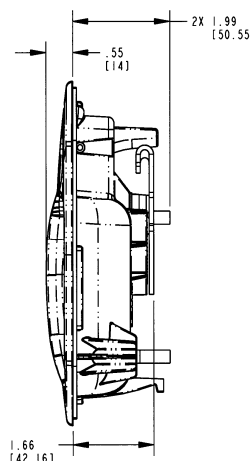
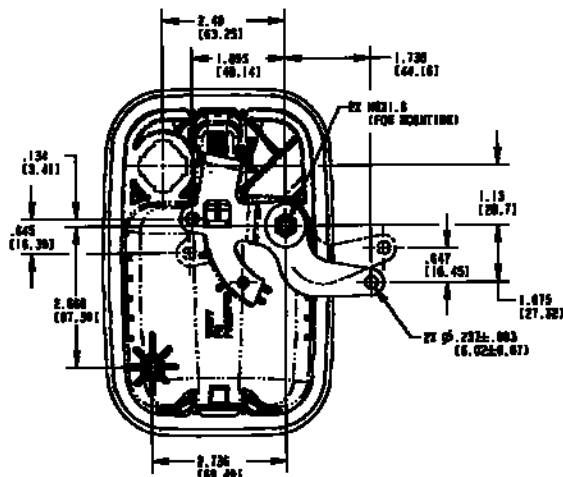
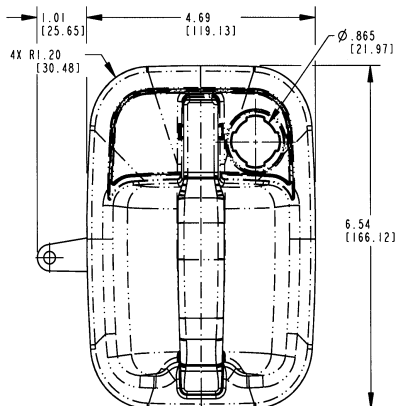

RECOMMENDED CUTOUT

For more information visit
www.trimarkcorp.com

020-0800 Surface Mounted Pull Handle

Designed specifically for off-highway vehicle applications that require a surface mounted exterior handle. This product allows greater ease of operation (ergonomics) than conventional push button or paddle handles and offers robust construction and rugged styling for a very cost effective price in a new handle category.

- Medium to heavy weight doors for off-highway vehicle applications
- Doors with high door seal loads or applications where a surface mounted pull type handle is more desirable than a push button or paddle handle

FEATURES/BENEFITS:

- Full gloved hand clearance
- Exterior surface mount along with the configuration of the actuator allows for mounting in any orientation
- Provides for greater ease of operation (ergonomics) than conventional push button or paddle handles
- Readily adaptable to a variety of door thickness with adjustable connecting link assembly
- Handle is rigid when locked

MATERIAL:

- Handle: glass reinforced nylon
- Brass threaded inserts



AVAILABLE:

- Can be keyed alike with most single and reversible key systems
- With gaskets and spacers to facilitate mounting and provide resistance to water and dirt infiltration
- Connecting link assembly

INSTALLATION:

- Mounts against glass with only 2 holes or steel with conventional mounting (see recommended hole pattern)
- Installed with (3) M6 X 1.0 bolts (not included)
- Recommended mounting fastener torque to be 5.6-6.7 N-m (50-59 lbf-in)

CAUTION: Handle does not meet the locking requirements for FMVSS 206

Design Patent No. D506,377

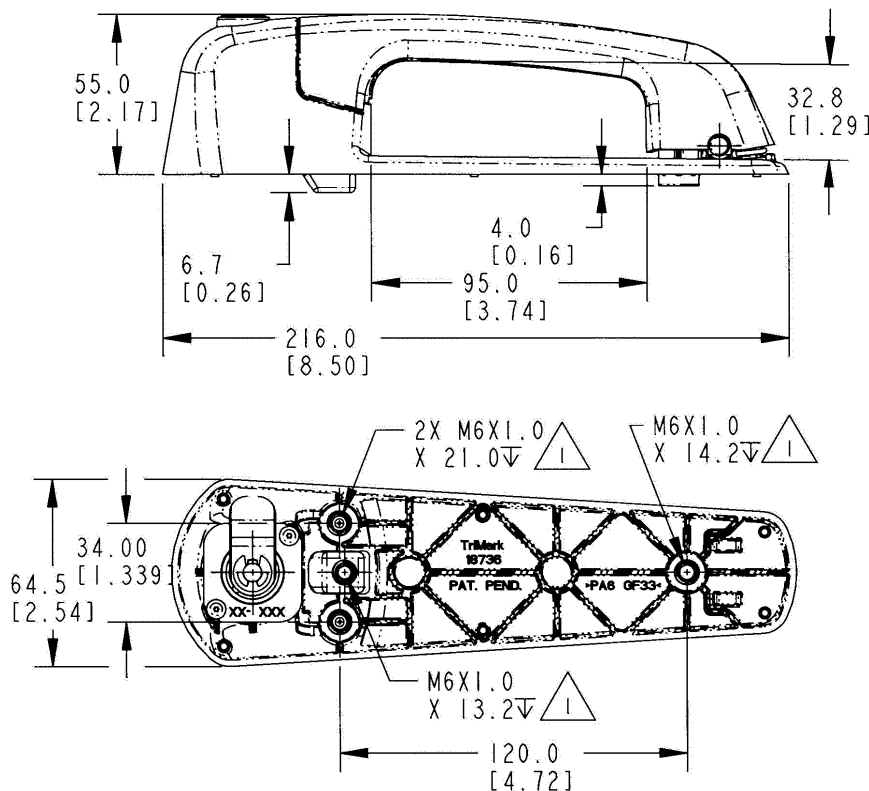

020-1100 Remote Pull Handle

This new product is designed for entrance doors on RV and specialty vehicles where it is desirable to have the exterior handle remotely mounted from the inside release and rotary latch. It features a large automotive styled exterior pull handle and latch mechanism and is adaptable for power locking.

- Entrance doors with thickness of 1-1/2" (38.1mm) minimum

FEATURES/BENEFITS:

- Smooth opening/closing action
- Comfortable finger access
- Adaptable for power door lock actuation
- Non-handed design--the pull handle can be mounted in vertical or horizontal orientations
- Molded gasket for flange of housing and paddle leg provides resistance to water infiltration

AVAILABLE:

- Master keyed lock key cylinder
- Lock can be keyed to match other TriMark door products with KeyOne™ Plus for a single-key system, keyed alike or provided non-locking
- Non-locking version
- Molded gasket for flange of housing provides resistance to water infiltration



INSTALLATION:

- Easy to install with 4 - #8-32 UNC mounting screws (not included)
- Recommended mounting torque 30 in/lbs

MATERIAL:

- Sturdy die cast zinc alloy paddle and housing
- Molded gaskets (included)

FINISH:

- Black powder coated housing with black powder coated or chrome plated handle
- Optional chrome plated housing

NOTE: Meets FMVSS 206 locking requirements and may be used in FMVSS 206 applications pending TriMark application approval.

Design Patent No. D564,855

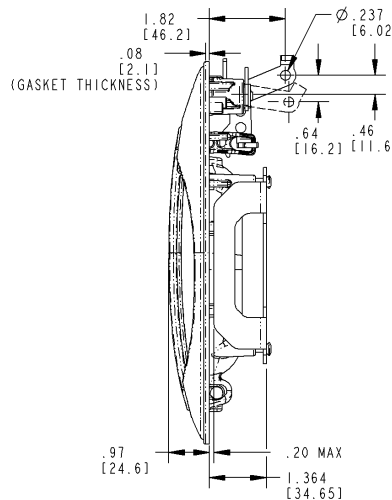
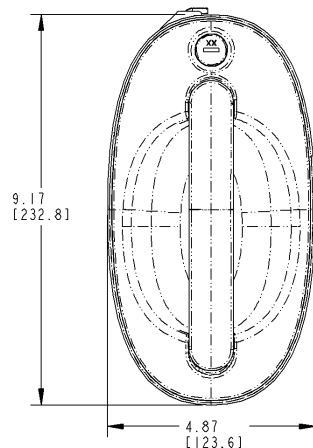

For more information visit
www.trimarkcorp.com

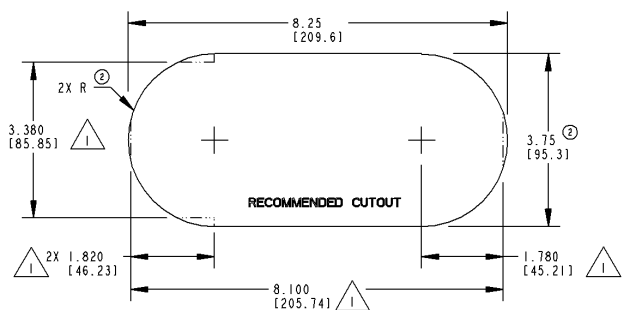
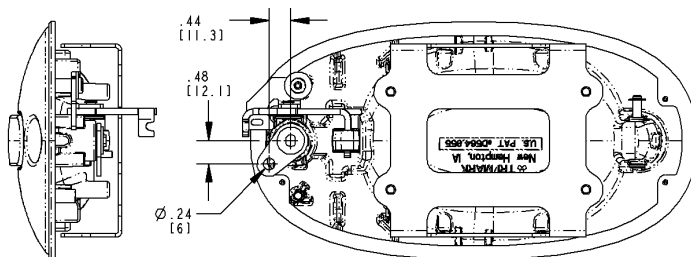

△ ALTERNATE CUTOUT OPTION.

Handles:
Pull Type

76

TriMark
www.trimarkcorp.com

020-1150 Two-Point Free Float Pull Handle

This new product is designed for entrance doors on RV and specialty vehicles where it is desirable to have the exterior handle remotely mounted from the inside release and rotary latch. It features a large automotive styled exterior pull handle and is adaptable for power locking.

DESIGNED FOR:

- Entrance and compartment doors with thickness of 2" (50.8mm) minimum

FEATURES/BENEFITS:

- Automotive style pull handle and latch mechanism
- Smooth opening/closing action
- Comfortable finger access
- Adaptable for power door lock actuation
- Non-handed design
- The pull handle can be mounted in vertical or horizontal orientation
- Molded gasket for flange of housing and paddle leg provides resistance to water infiltration

AVAILABLE:

- Master keyed lock key cylinder
- Lock can be keyed to match other TriMark door products with KeyOne Plus for a single-key system, keyed alike or provided non-locking



The 020-1150 is not available for sale to the ambulance market or any patient transport vehicle until further notice.

INSTALLATION:

- Easy to install with (4) #8-32 UNC mounting screws (not included)
- Recommended mounting torque 30 in/lbs (3.4 N-m)

FINISH:

- Black powder coated housing with black powder coated paddle or chrome plated paddle
- Optional chrome plated housing

MATERIAL:

- Sturdy die cast zinc alloy paddle and housing
- Molded gaskets (included)

Meets FMVSS 206 locking requirements and may be used in FMVSS 206 applications pending TriMark application approval.

Design Patent No. D564,855

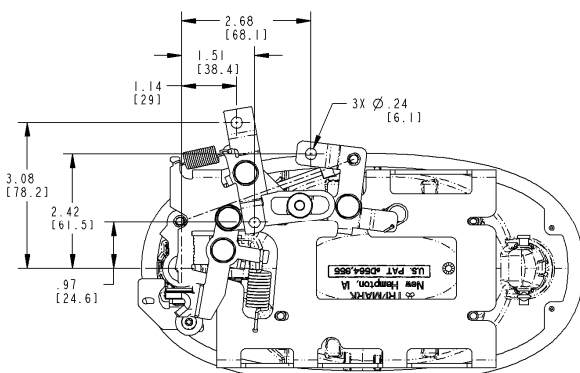

Horizontal Handle Mounting With Horizontal Rod Pull

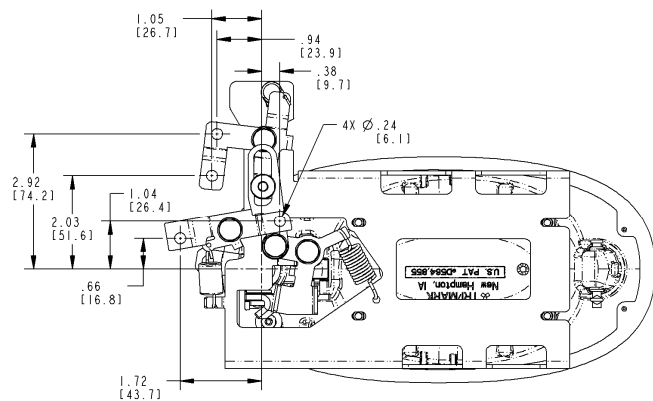

Horizontal Handle Mounting With Vertical Rod Pull

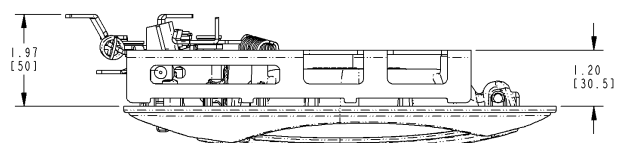
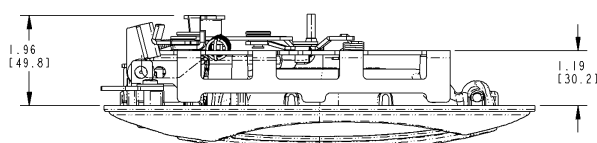

040-0100 Push Button Handle

DESIGNED FOR:

- Off-highway applications -- construction, mining, agricultural
- Outside latch release
- Entry assist

FEATURES/BENEFITS:

- Frictionless push button seal
- Flow through self-cleaning design
- Readily adaptable to a variety of door thickness with a 1/4" diameter capscrew

MATERIAL:

- Die cast zinc alloy

FINISH:

- Black powder coated
- Copper-nickel-chrome

INSTALLATION:

- Installed with (3) M6x1 bolts
- Spacers are available to mount the handle on a flat surface



For more information visit
www.trimarkcorp.com

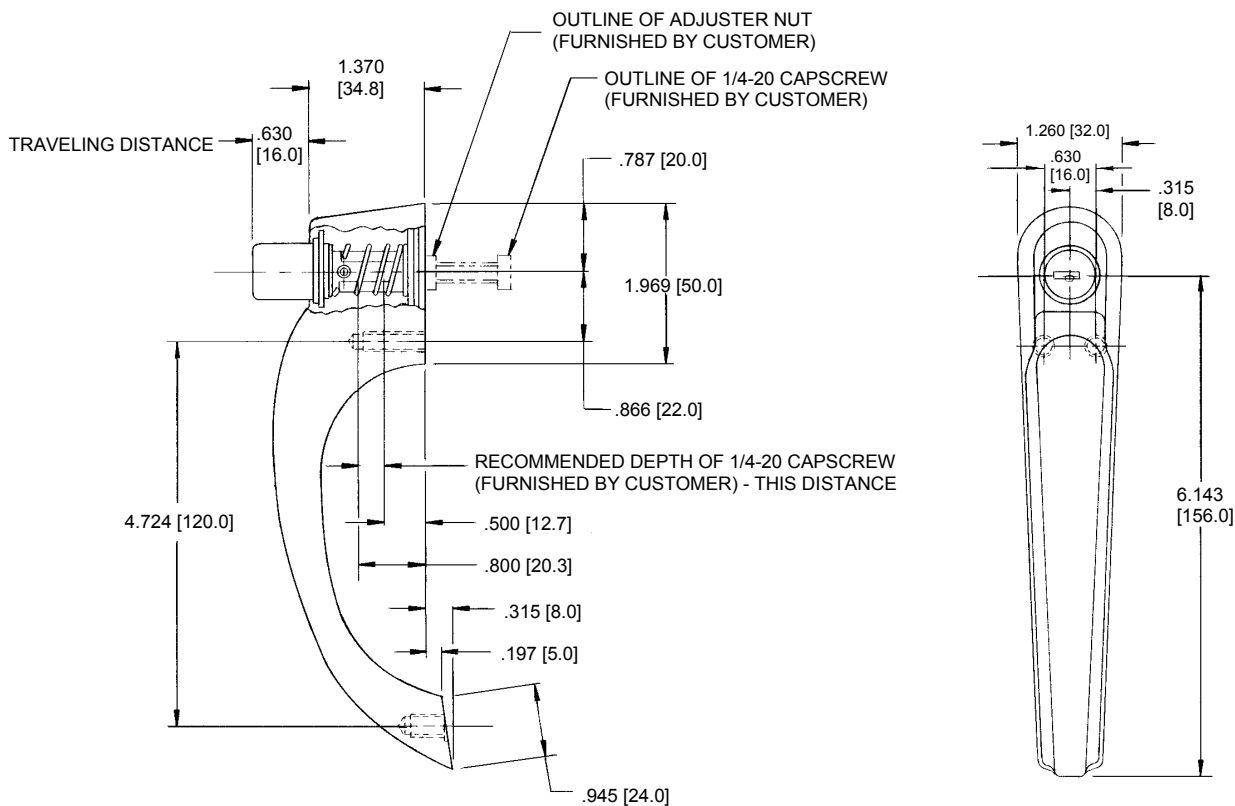

040-0300 Non-Metallic Push Button Handle

This handle was specifically designed for off-highway vehicle applications that require a surface mounted exterior push button handle. It offers robust construction and ergonomic function in a rugged engineering grade plastic.

- Off-highway applications -- construction, mining, agricultural
- Outside latch release

FEATURES/BENEFITS:

- Frictionless push button seal
- Flow through self-cleaning design
- Readily adaptable to a variety of door thicknesses with a 1/4" diameter capscrew
- Mounts against glass with only 2 holes (see next page)
- Available keyed alike or keyed random

MATERIAL:

- Glass reinforced nylon
- Brass threaded inserts

INSTALLATION:

- Installed with (3) M6 X 1 bolts (not included)



For more information visit
www.trimarkcorp.com

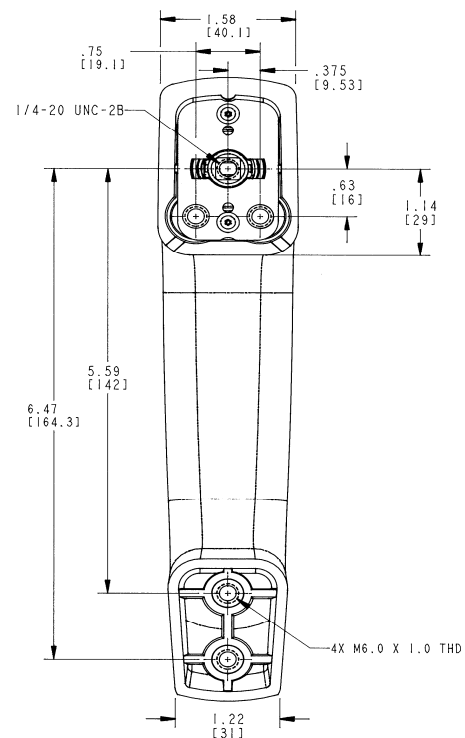
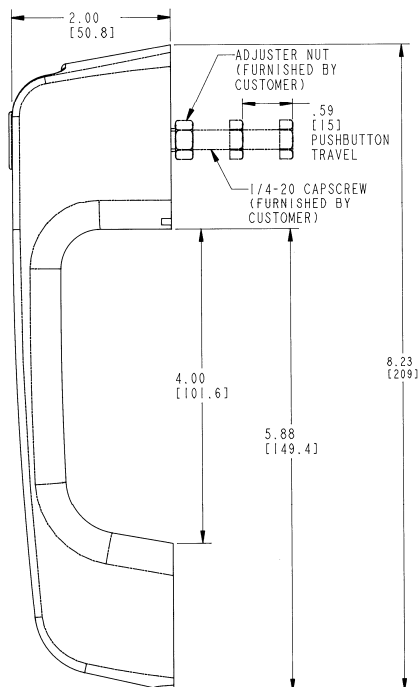

040-0600 TriMount Push Button Handle

The 040-0600 TriMount Push Button Handle was specifically designed for off-highway vehicle applications that require a surface mounted exterior push button handle with 120mm or 163mm mounting pattern. It is retrofits with most European push button handles and offers robust construction, ergonomic function and styling for a very cost effective price.

FEATURES/BENEFITS:

- Retrofittable with most European push button handles
- Universal mounting is available in 3 different mounting configurations: 2 bolt 120mm, 3 bolt 120mm and 2 bolt 163mm mounting
- Frictionless push button seal
- Readily adaptable to a variety of door thickness with an adjustable bolt and nut
- Full gloved hand clearance
- 15.88mm (.625) button travel
- Easy to operate (ergonomics)

MATERIAL:

- Handle: glass reinforced nylon
- Brass threaded inserts

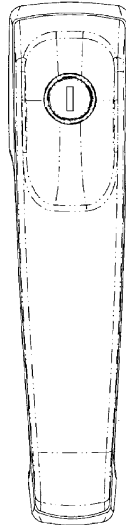
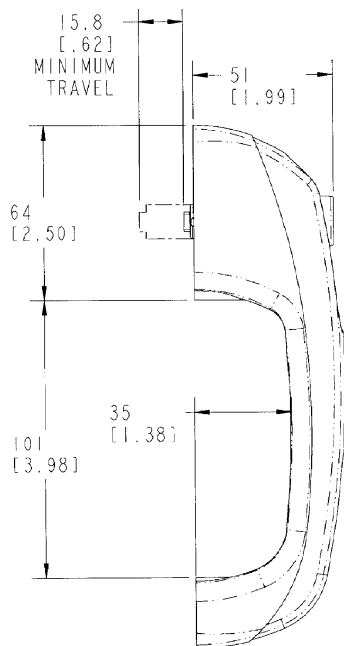

AVAILABLE:

- Can be keyed alike with most single and reversible key systems or non-locking configurations
- Locked rigid or free-floating versions
- With bezels or gasket sets to facilitate mounting and provide resistance to water and dirt infiltration (sold separately)

INSTALLATION:

- Installed with (2 or 3) M6 X1.0 bolts (not included)
- Mounts against glass with only 2 holes
- Recommended mounting fastener torque to be 5.6 - 6.7 N-m (50-59 lbf-in)

Design Patent No. D461,391

ADJUSTABLE BOLT, NUT
AND PLASTIC ADJ. END

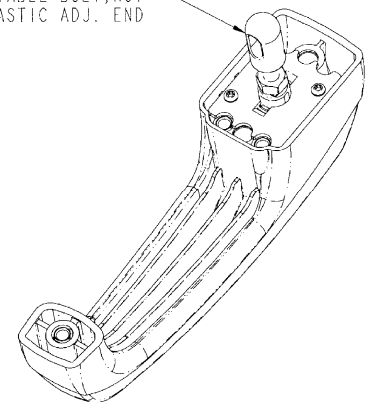

ROTATING CAM

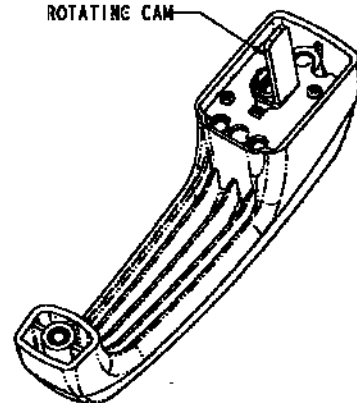

For more information visit
www.trimarkcorp.com

040-0700 Lift and Latch Handle

The 040-0700 Lift and Latch Handle is designed to operate on back hoe loader and excavator vertical opening windows for full unobstructed vision. Latching is provided in the 'fully open' or overhead position, and in the 'closed' front latched position. This integrated latching and handle solution features full gloved hand clearance, one-touch action release and slam action retention providing safe and secure operation.

DESIGNED FOR:

- Medium to heavy-duty on-highway vehicle vertical windows where movement up and over is designed

FEATURES/BENEFITS:

- Easy to operate (ergonomics), operator handle is gas injected which gives automotive feel and appearance
- 12mm plunger travel provides secure engagement into window tracks
- Right and left hand configuration is sold as a pair
- Manufactured in injection molded engineered plastic to save weight
- Lower cost compared to zinc die cast versions

MATERIAL:

- Handle/Plunger: Glass reinforced nylon



INSTALLATION:

- Push button handle with 195mm mounting pattern — retrofits with most European up and over handles
- Installs easily with (4) M6 mounting fasteners (not included)

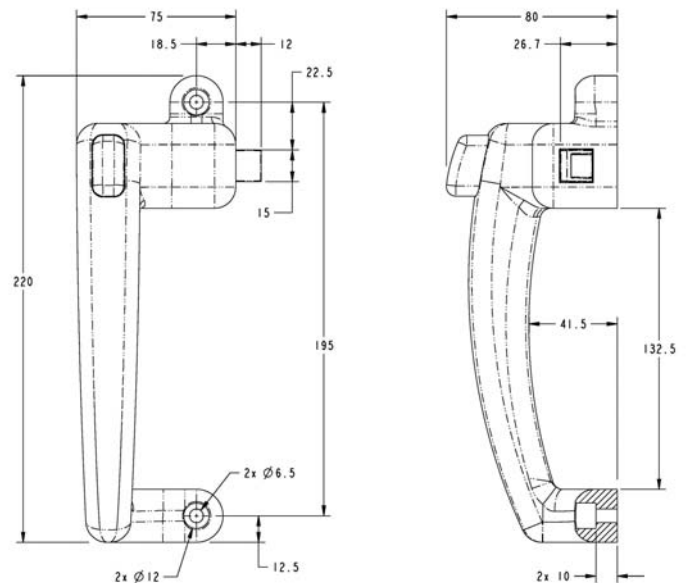

For more information visit
www.trimarkcorp.com

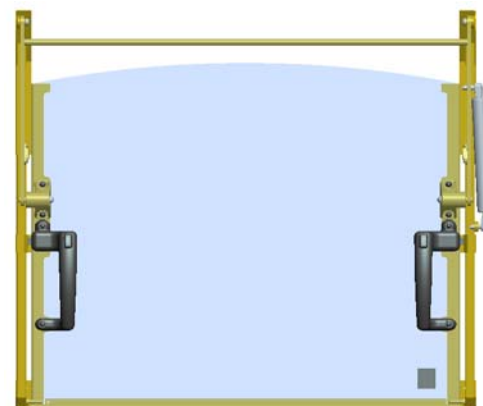

040-1400 Push Button Center Control

This handle was designed for toppers, lift-gate and baggage doors and features a push button actuation and a two-point bellcrank linkage. Installation is easy with either a threaded panel nut or spring clip.

- Door thickness up to 1/4" (6.35mm)

FEATURES/BENEFITS:

- Push button actuation versus typical twist action
- Durable and weather resistant construction
- Ergonomically shaped finger pull
- Housing flange gasket, push button o-ring and shuttered keyplug for reducing water and dirt infiltration
- Bypass lock mechanism allows push button to free-travel when locked for added security

INSTALLATION:

- 1-1/8" (28.6mm) panel nut to secure escutcheon to the door
- Spring clip to attach linkage to escutcheon

MATERIAL:

- Housing, push button and mounting nut: die cast zinc
- Linkage, finger pull and lock cam: mild steel



FINISH:

- Escutcheon and finger pull: black powder coated
- Push button: buffed chrome or black powder coated
- Steel components: zinc plated with chromate conversion coating

AVAILABLE:

- Custom finger pulls (please inquire)
- Optional anti-spin washer
- Keyed random. Over 50 key codes available
- Without bellcrank linkage as stand alone push button

U.S. Patent No. 6,231,091

For more information visit
www.trimarkcorp.com

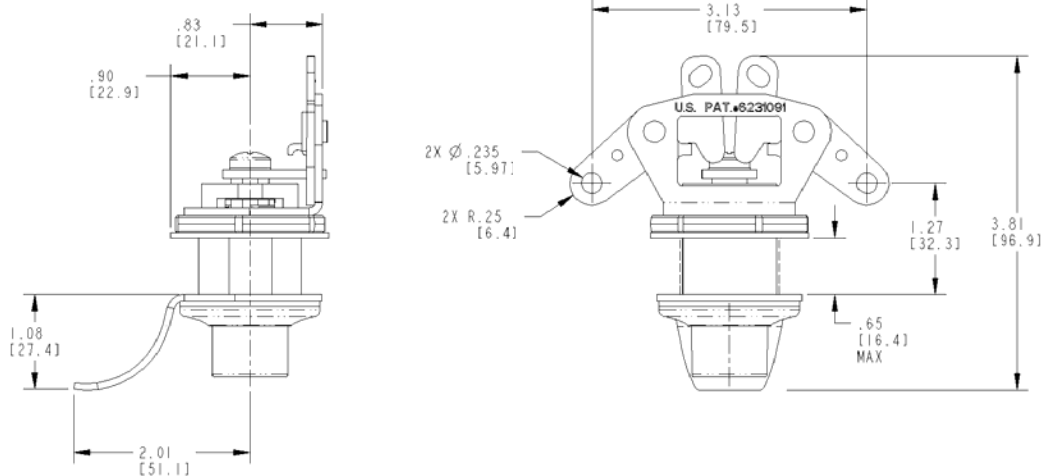

010-0100 Release Lever

Designed for an inside release for the use on L-handles, this product offers a simple low cost handle for use on rotating drive bar applications.

AVAILABLE:

- With 5/16" square hole at 90 degree and 45 degree orientation

MATERIAL

- Die cast zinc alloy

FINISH:

- Mill—un-plated
- Copper-nickel chrome plated
- Black powder coated

INSTALLATION:

- .156" (4.0mm) diameter roll pin (not included)
- 5/16" diameter set screw

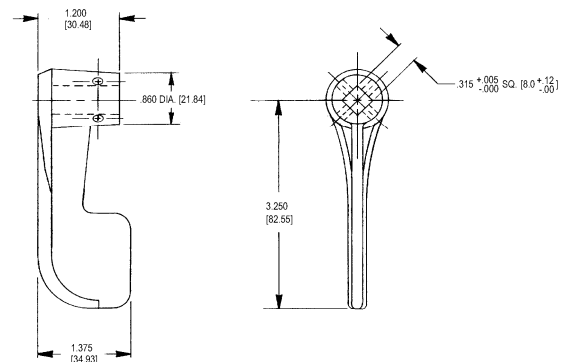

For more information visit
www.trimarkcorp.com

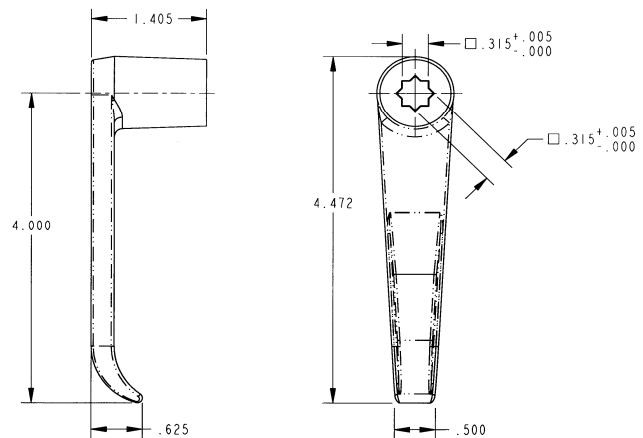
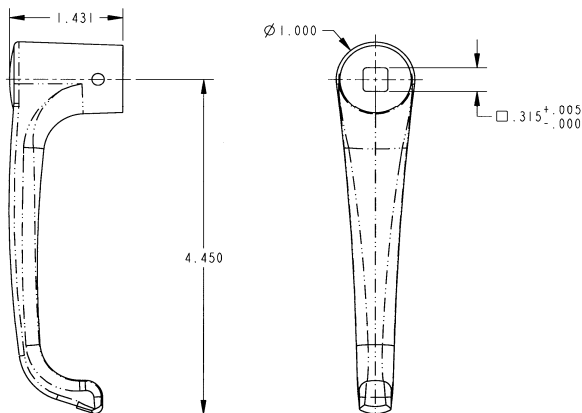

010-0200 Non-Locking / 010-0300 Locking L-Handle

Non-locking L handles provide simple interior/exterior rotating handle functions for surface mounted applications.

- General purpose use for off-highway cab doors or storage, compartment and access doors for on or off-highway applications

FEATURES/BENEFITS:

- Ample finger clearance
- Easily installed with oval or flat head No. 10 fasteners (not included)
- Locking L-handle assembly provides 360° rotation and locks at 90° increments

AVAILABLE:

- Mounting hole patterns and escutcheons (bases) for different finger clearances
- Drive bar lengths, with or without holes or threaded rods
- Keyed CH751 and other key codes
- Drive bar attached to handle by drilling and pinning
- Locking or non-locking:
 - Standard finger clearance (Type 1 and 2)
 - Extended finger clearance (Type 4)
 - Low profile (Type 3)
- 1.50 (3.81mm) or 1.75 (4.45mm) mounting hole spacing



FINISH:

- Handle and escutcheon: copper-nickel chrome plated; or black powder coated
- Drive bar: mill finish

MATERIAL:

- Handle and escutcheon: die cast zinc alloy
- Drive bar: mild steel

SPECIFY WHEN ORDERING:

- Series number
- Escutcheon type
- Drive bar length (L1) and optional hole location (L2)

Standard Finger Clearance (Type 1)

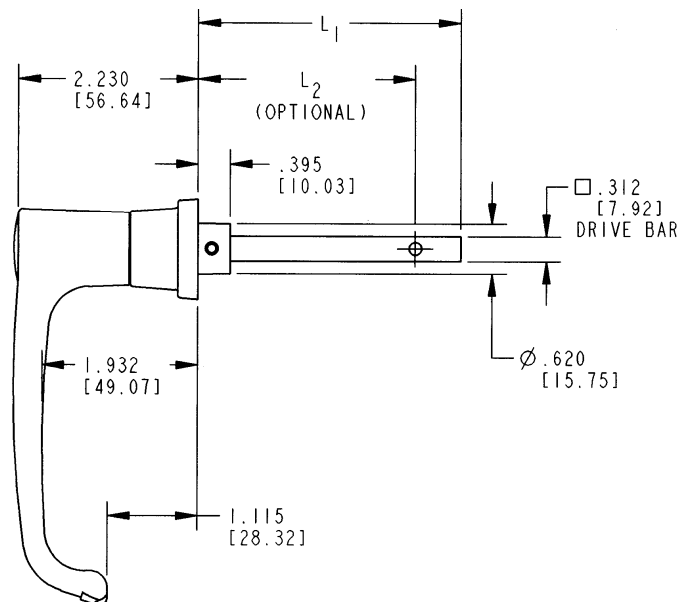
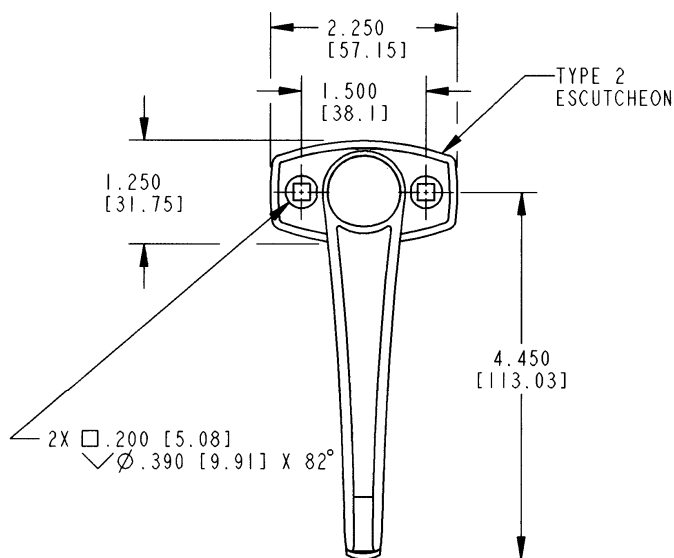

Standard Finger Clearance (Type 2)

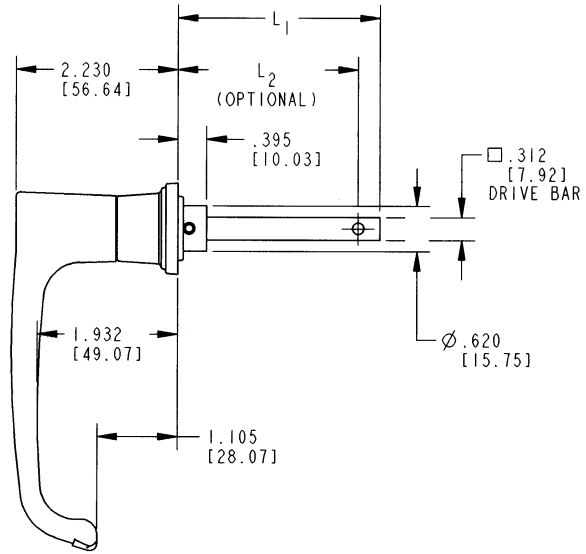
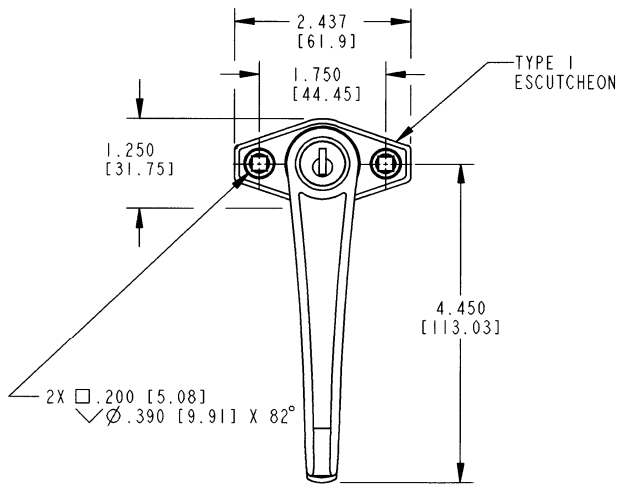

Low Profile (Type 3)

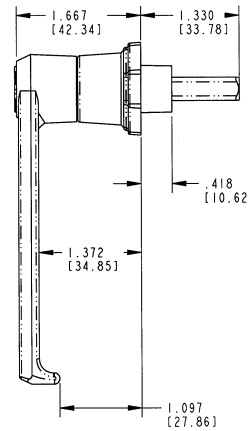
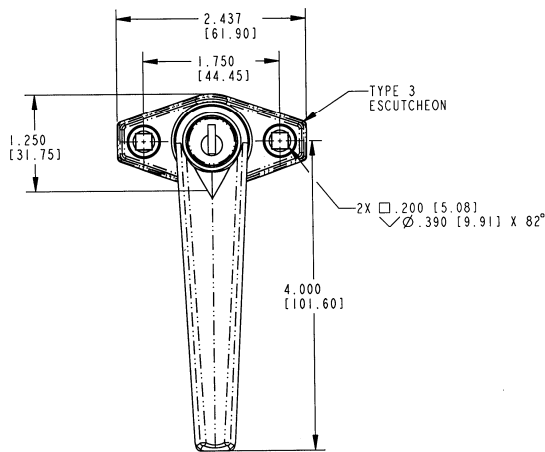

Extra Finger Clearance (Type 4)

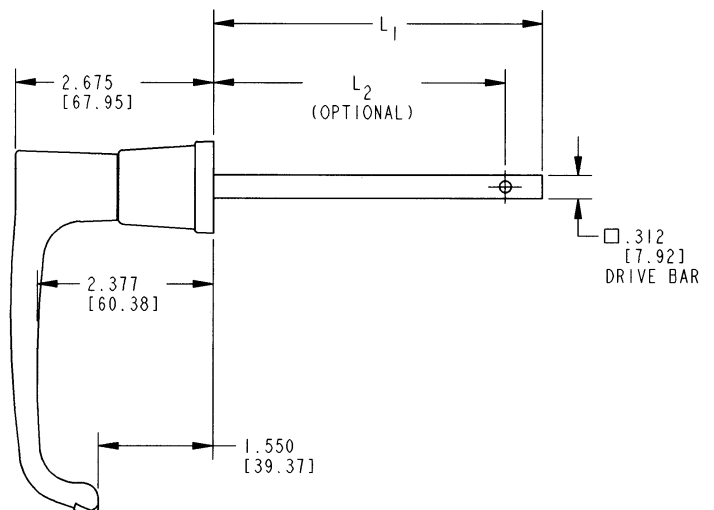
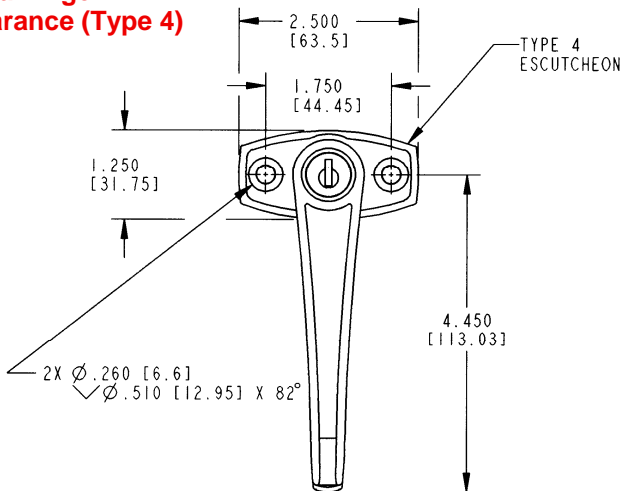

010-0600 Flush Mounted Pop-Up T-Handle

This handle was designed for toppers, lift gate and baggage doors where 1/4 turn cam locking is desired. It features a low profile handle that pops up when actuated for ease of use and is available in several rotations, drive bar lengths and finishes.

- Garage doors, storage and access doors
- Any application where low profile hardware is important

FEATURES/BENEFITS:

- Flush mounted - when "T" handle is depressed, rivets and fastener heads are concealed
- Rubber gasket under base provides resistance to water infiltration

AVAILABLE:

- Key lockable with 50 key codes available or keyed alike. Non-locking version is also available
- 1 or 2-point locking
- 90° or 150° rotation
- 2.500" (63.5mm) or 3.500" (88.9mm) drive bar lengths
- Clockwise or counterclockwise rotation



MATERIAL:

- Shuttered keyway: stainless steel
- All major components: zinc alloy
- Drive bar: zinc plated steel
- Internal (2) springs: stainless steel

FINISH:

- Black powder coated or white

INSTALLATION:

- Easy installation with (2) No. 10 fasteners or rivets
- Recommended door mounting - 1.125 (28.6mm) diameter thru hole

For more information visit
www.trimarkcorp.com

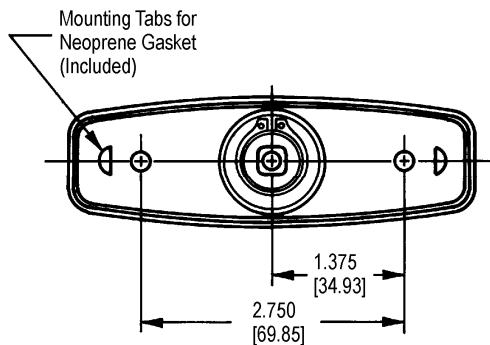

DRIVE BAR CHART

Dimension "D"

2.500 [63.5]

3.500 [88.9]

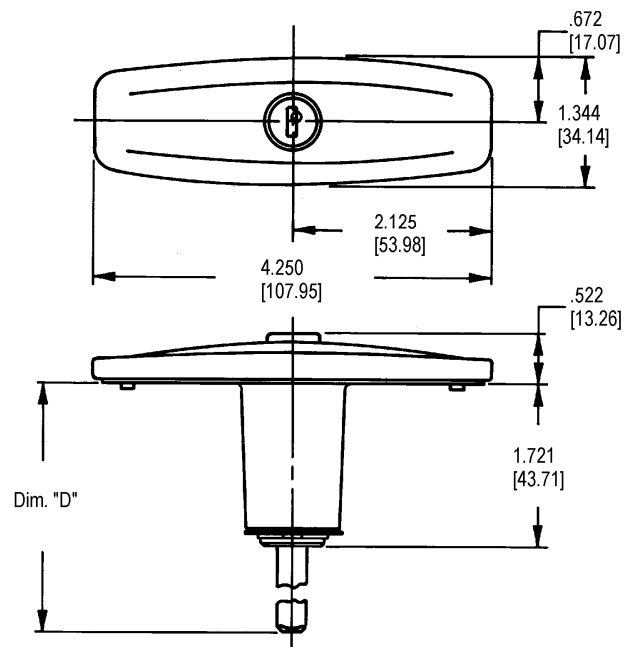

010-0700 Light Duty Compartment Latch

This handle was designed for small compartment and access doors and tool boxes where 1/4 turn cam locking is desired. Available in both locking and non-locking, the non-locking version features a detent function in both the latched and unlatched positions.



AVAILABLE:

- Locking configuration: keys furnished with assembly
- Non-locking configuration: detent in latched and unlatched positions
- 90° rotation

MATERIAL:

- Handle: die cast zinc alloy
- Cam: zinc plated steel

FINISH:

- Copper-nickel-chrome plated
- Black powder coated

INSTALLATION:

- Supplied either fully assembled or bagged with cam and nuts packaged loose
- Removal of cam and 7/8-28 mounting nut is required for installation. IMPORTANT: Note maximum nut torque specifications below.

For more information visit
www.trimarkcorp.com

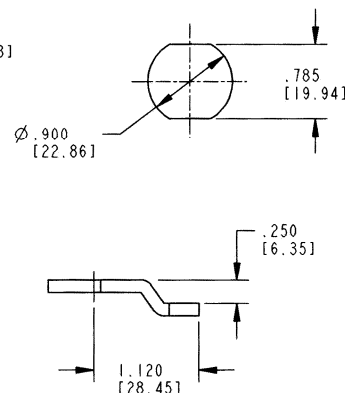
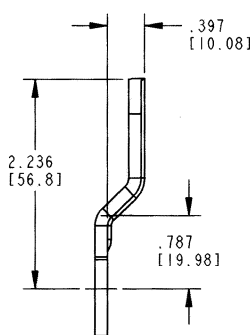
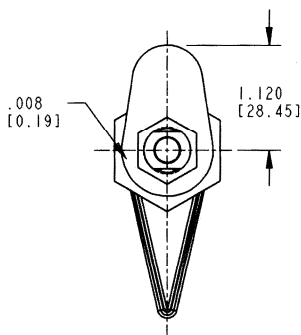
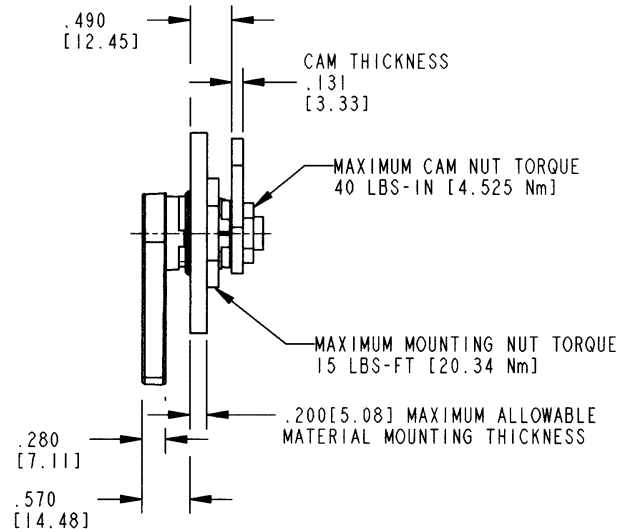
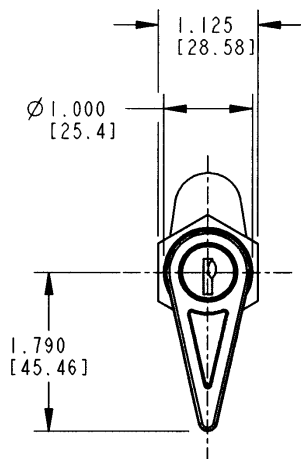

010-1100 TriGuard Heavy-Duty Rotating Handle

This robust exterior L-handle features modular construction that allows for customization, including the use of light weight materials without sacrificing strength. The handle also allows for use of a padlock for security

- Entrance and rear door application for heavy-duty vehicles
- Interior and exterior applications
- Medium to heavy duty doors of 23-455kg (50-1000 lbs.)

FEATURES/BENEFITS:

- Heavy duty modular construction
- Padlockable for additional security or non-locking versions available
- Modular construction allows for serviceable handle components disassembly

AVAILABLE:

- Standard steel handle version or available with lightweight aluminum handle
- Right or left hand rotation versions available
- Customization features available. Please inquire
 - ◆ Mounting details—door thickness
 - ◆ Length of handle
 - ◆ Handle materials

MATERIAL:

- Standard — high strength steel construction
- Available with advanced lightweight aluminum alloy handle



FINISH:

- Standard low gloss black powder coated
- Mil-Spec soft grip nylon coated handle
- 1000 hour corrosion protection
- Optional finishes available including: Black Magni™ coating, Tan/Olive CARC paint and Tan/Olive powder coating

INSTALLATION:

- Easy to install, mounts with single 1.250—20 UN threaded nut
- Tighten to the manufacturers' recommended torque value, however, do not exceed 405 N-m (295 ft-lb)
- Mounting nut and lock washer included

Patent Pending

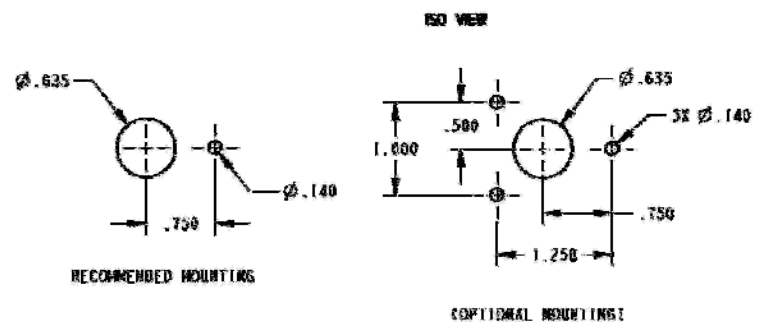
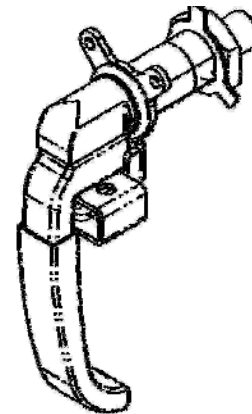
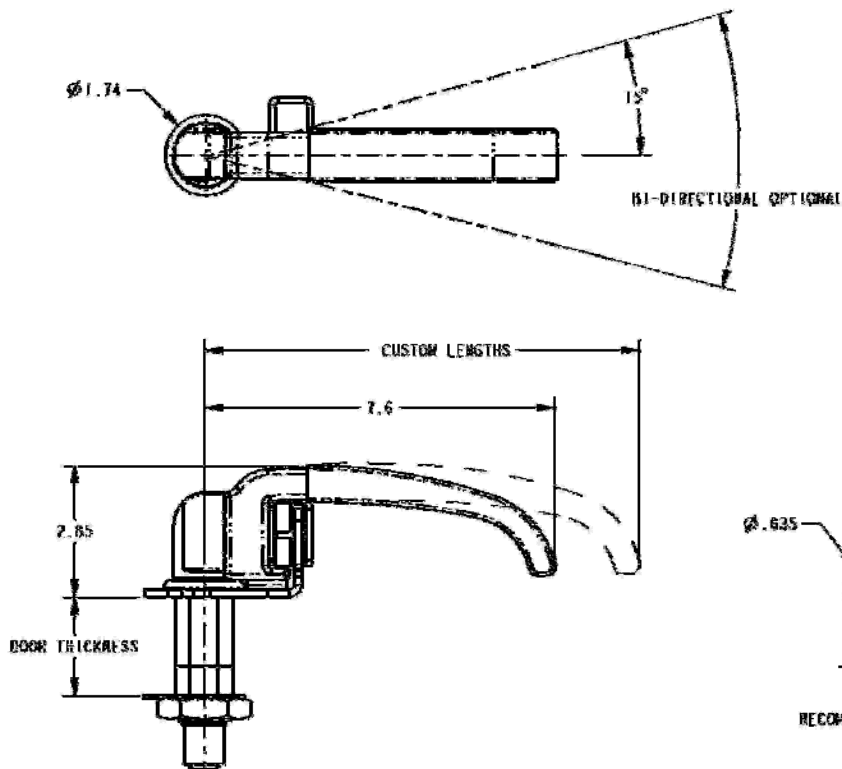

020-0150 Grab Handle

This stylish entry assist handle for RV coaches, motor homes and travel trailers is available with a lighted acrylic bar for safety and convenience.

FEATURES/BENEFITS:

- Offers modern styling with premium look and feel
- Rugged and durable construction
- Perfect interior complement for the 540-0200 Lighted Grab Handle With Keypad (e-GRAB)

AVAILABLE:

- With or without handle rod light
- Handle rod can be personalized with manufacturer's name, model and logo
- Your choice of handle lengths

INSTALLATION:

- Easy to install with (8) 1/4" or M6 fasteners (not supplied)

FINISH:

- High quality polished copper-nickel-nickel chrome is durable and stylish

MATERIAL:

- Sturdy zinc die cast alloy mounting end caps
- Cast acrylic rod in clear finish

Design Patent No. D559,653

For more information visit
www.trimarkcorp.com



A	458 [18"]	495 [19.5"]
B	390 [15.3"]	427 [16.8"]
C	357 [14.0"]	395 [15.5"]

