

030-0175  
Stamped Steel  
Compartment Latch



This compartment latch was designed for light to medium duty storage and compartment doors. Available in buffed stainless steel or plated mild steel, this product features an integrated rotary latch for ease of installation and use and is available in a power lock version.

**DESIGNED FOR:**

- On or off-highway vehicle applications
- Service and utility truck body doors
- Fire and rescue unit vehicles
- Most storage, compartment and access doors with latch and strike location at top or sides of door
- Door weights of approximately 75 lbs. (34 kg) or less



[www.trimarkcorp.com](http://www.trimarkcorp.com)

**TriMark Corporation**

500 Bailey Avenue  
P.O. Box 350  
New Hampton, Iowa 50659  
United States  
Tel: 641-394-3188  
Fax: 641-394-2392  
1-800-447-0343  
[www.trimarkcorp.com](http://www.trimarkcorp.com)

10002707 QM08 ISO 9001: 2008  
10002707 TS09 ISO/TS 16949: 2009  
The UL logo, consisting of the letters 'UL' inside a circle with 'UL' written vertically on the sides.  
**TriMark Corporation**

**TriMark Europe**

Cedar Court  
Walker Road  
Bardon Hill  
Coalville LE67 1TU  
United Kingdom  
Tel: +44(0)1530 512460  
Fax: +44(0)1530 512461  
[www.trimarkeu.com](http://www.trimarkeu.com)

427961 QM08 ISO 9001 : 2008  
427961 UM ISO 14001 : 2004  
The UL logo, consisting of the letters 'UL' inside a circle with 'UL' written vertically on the sides.  
**TriMark Europe Ltd.**



# 030-0175 Stamped Steel Compartment Latch

### AVAILABLE:

- In locking or non-locking configurations
- Keyed alike
- Keyed random. 50 keycodes available
- 2-point pivot plate for doors that require a 2-point latching mechanism (030-0185)
- Optional gasket for flange of housing is available to provide resistance to water and dirt infiltration
- Power lock actuation
- Customer logo on paddle (please inquire)

### FINISH:

- Buffed and polished stainless steel
- Zinc plate clear chromate conversion coat over mild steel for maximum paint adhesion and resistance to rust

### MATERIAL:

- Housing and paddle: 300 series stainless steel
- Mild steel also available on housing and paddle
- Other components: zinc plated, mild steel
- Internal latch components: case hardened, smooth edge stamped steel
- Stainless steel non-corrosive springs and rivets

### INSTALLATION:

- 3/16" (4mm) diameter fasteners
- Blind mount option also available

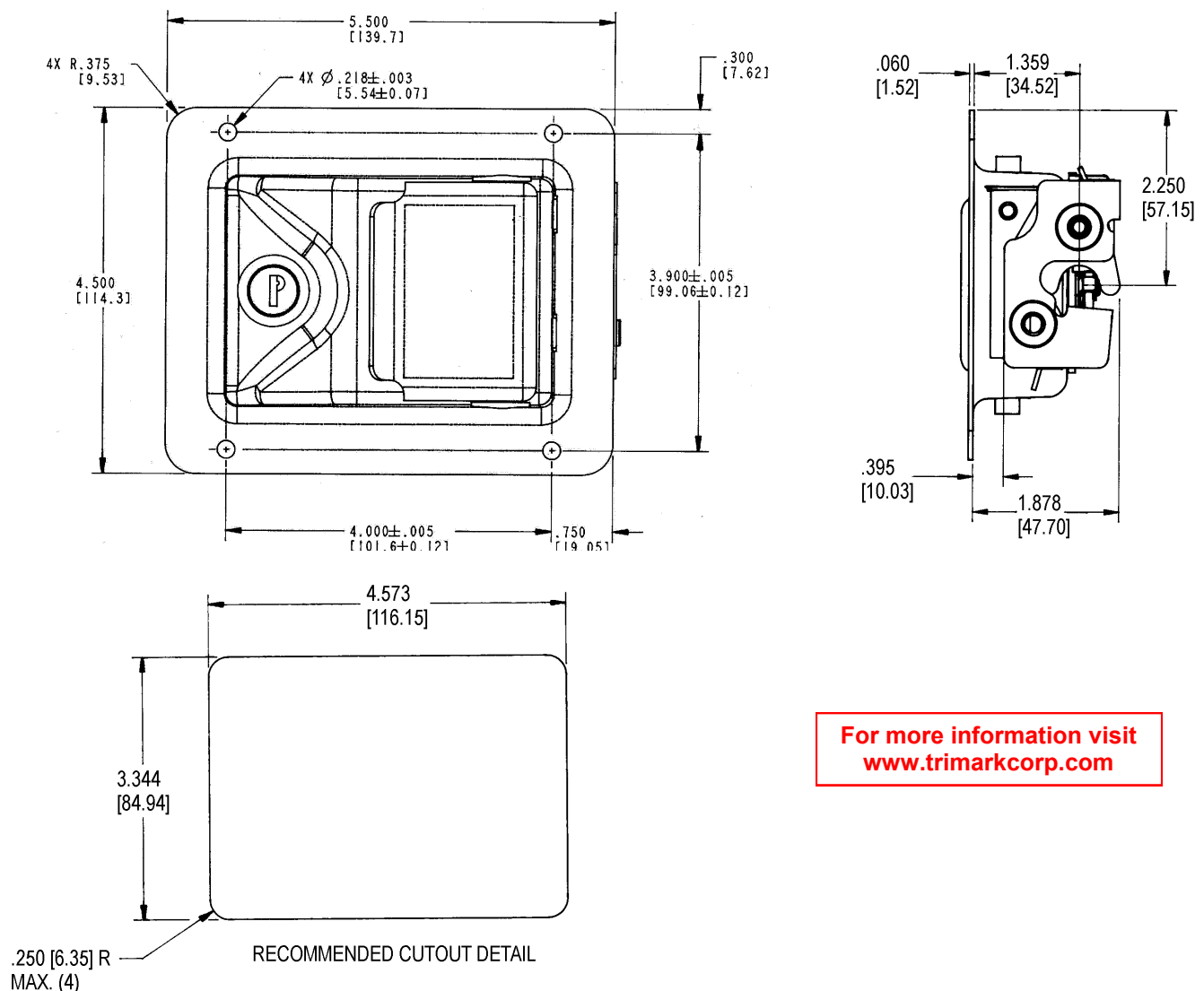

For more information visit  
[www.trimarkcorp.com](http://www.trimarkcorp.com)

**APPLICATION RECOMMENDATIONS:**

- Striker bolt installation should allow for a minimum radial movement of .060 [1.524] for adjustment
- Rubber bumpers or door seals are recommended to reduce effects of vibration stress on door and latch system

**Caution:** Compartment latch does not meet FMVSS 206 load requirements.

**Individual part dimensions are for reference only. Refer to individual part drawings for complete dimensions, specifications, and installation procedures. Engineering assistance and application drawings are available.**

**LATCH & STRIKER INSTALLATION:**

- Install striker bolt in door frame
- Close door carefully and check for interference between head of striker bolt and latch components
- Add or remove shims under striker bolt washer as required (outside diameter of shim should be larger than outside diameter of striker bolt washer)
- Adjust striker bolt vertically so door is not guided upward or downward while being closed
- CHECK TO DETERMINE THAT BOTH SECONDARY AND PRIMARY LATCH POSITIONS ARE USABLE
- Door should be latched but not "closed" in secondary position and latched to anticipated "closed" position with respect to adjacent surfaces in primary position
- If both primary and secondary positions are not evident, readjust striker bolt

