

TriMark's e-ASK System

electronic Access & Security Keyless-entry



Entrance doors, compartment doors or baggage doors, RF transmitter fob, keypad or both...now you can have it all. Keyless convenience and security is just a simple push of a button.



500 Bailey Avenue
P.O. Box 350
New Hampton, Iowa 50659
United States
Tel: 641-394-3188
Fax: 641-394-2392
1-800-447-0343
www.trimarkcorp.com



TriMark Europe
Cedar Court
Walker Road
Bardon Hill
Coalville LE67 1TU
United Kingdom
Tel: +44 (0)1530 512460
Fax: +44 (0)1530 512461
www.trimarkeu.com



TriMark's e-ASK Systems

High Value



500-1100 e-FOB System

Increased Functionality

540-0100 e-PAD



500-1200 e-PAD System



Premium Features

540-0200 e-GRAB



500-1000 e-ASK System

TriMark has expanded its door systems expertise by adding electrical/electronic controls to its product offering. The addition of keyless electrical products adds a further dimension of functionality, convenience and security to our systems. This selection of compatible components allows for complete keyless entry for on or off-highway vehicle applications.

Electronic Access & Security Keyless-Entry provides either an e-FOB RF transmitter/receiver or a 5-button e-PAD for true keyless operation.

The system can be adapted to provide basal locking; on locking function to entry door(s) but also can be customized for controlling compartment doors, windows, ignition, lighting, horns, sirens, other security system features, etc.

TriMark ADVANTAGE:

- Advanced technology expertise
- Patented products
- Rugged and reliable systems for on and off-road applications
- Full service supplier
- Excellent design and applications support
- Integrated systems approach
- Global presence
- Ability to integrate with security systems
- Compatible with CAN SAE J1939, RV-C, and other multiplexing protocols

e-ASK PRODUCTS:

If security and convenience are two major attributes your customers demand, then TriMark is the answer. Full functionality and state-of-the-art design and manufacturing means you can depend on TriMark electronics to be working many years down the road.

- 500-1000 e-ASK System
- 500-1100 e-FOB System
- 500-1200 e-PAD System
- 540-0100 e-PAD Keypad
- 540-0200 Lighted Grab Handle With Keypad (e-GRAB)
- 550-0100 Power Lock Actuators



e-ASK, e-FOB, e-PAD, and e-GRAB are registered trademarks of TriMark Corporation

For more information visit www.trimarkcorp.com

540-0200 Lighted Grab Handle With Keypad (e-GRAB)

This new product incorporates TriMark's e-ASK keypad into a stylish entry assist handle combination for RV coaches, motor homes and travel trailers. Offering increased end user convenience with high end look and feel, the grab handle provides keyless entry, security, and convenience through a keypad electronics interface.

DESIGNED FOR:

- Entry assist handle incorporates TriMark's e-ASK keypad into a stylish combo for RV coaches, motor homes and travel trailers
- Incorporation with TriMark mechanical latches, handles and systems by providing keyless entry, security, and convenience for access door systems through a keypad electronics interface

FEATURES/BENEFITS:

- Increased end user convenience
- Offers modern styling with high end look and feel
- Rugged and durable construction is environmentally sealed for long life
- Lighted keypad and handle rod for more effective night time usage
- Tactile, visual and audio feedback with the ability to control the handle rod LED light also
- Can control numerous entry/compartments doors with independent control of multiple door zones

AVAILABLE:

- Multi-plex or discrete e-PAD Keypad (Reference platforms 540-0100 and 500-1000 for additional information)
- With or without door bell feature
- Handle rod can be personalized with manufacturer name, model, logo etched
- Complete kit with wire harnesses and other accessories
- With e-FOB remote transmitter integration
- With security system integration

FINISH:

- High quality polished copper-nickel-nickel chrome is durable and stylish

MATERIAL:

- Sturdy zinc die cast alloy housing, cover and end cap
- Cast acrylic rod in clear or frosted finish

Patents Pending

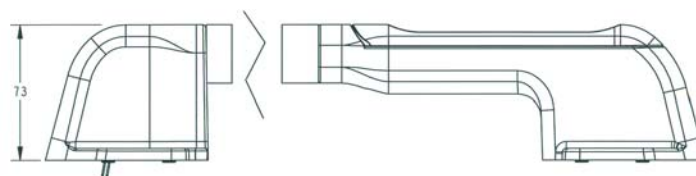
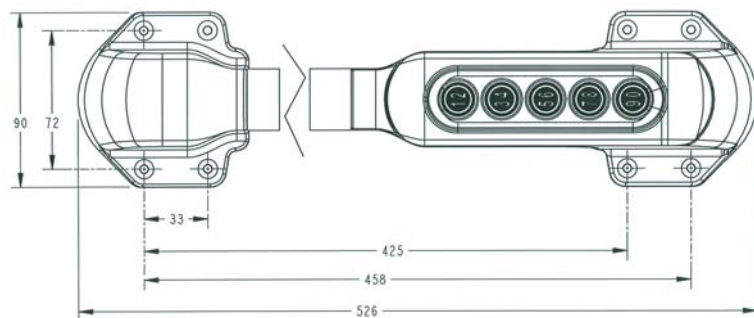

500-1000 e-ASK System

TriMark's top level e-ASK system consists of a selection of compatible components that allow for complete keyless entry for on or off-highway vehicle applications. Keyless-entry incorporation into TriMark mechanical latches, handles and systems provides additional security and convenience for access door systems. This system includes both a touch pad and remote fob transmitter for the ultimate in end user convenience and functionality.

FEATURES/BENEFITS:

- Easy and intuitive to operate
- Rugged and durable construction is compliant to on-road, off-road, and industrial environmental requirements
- I/O module with on-board locking and unlocking relays
- Can control up to 20+ entry/compartments doors (expandable) and utilizes staggered door control for minimized current draw
- Multiplexing communications
- Locking/unlocking confirmation
- Ignition controlled auto-locking
- Ability to provide 5 OEM definable functions from keypad, including ability to unlock one side of motor home baggage doors at a time
- 3 security system inputs (ability to sense entry door(s) and baggage door(s), and other security system devices such as glass break and motion detectors)
- 3 variable timed light activation output (porch, compartment or interior lighting)



AVAILABLE:

- Standard kit make up includes: keypad, 2 pre-trained RF remote fob transmitters, RF receiver, I/O module, harness connecting receiver and I/O module, gasket, push button switch, LED assembly, key rings and manual
- Customized wire harnesses
- Additional fob transmitters
- 2 different programming functions; standard mode, and cargo mode. Standard mode allows for the lock/unlocking of doors plus panic mode and one auxiliary output (controls lighting, opens compartment etc.). Cargo mode allows for the lock/unlocking of main personnel doors plus independent control of many cargo/compartments doors.

This product is covered by one or more of the following:
U.S. PATENT NO. 6,789,003
U.S. PATENT NO. 7,034,655
U.S. PATENT NO. 7,119,709
DESIGN PATENT D486,376

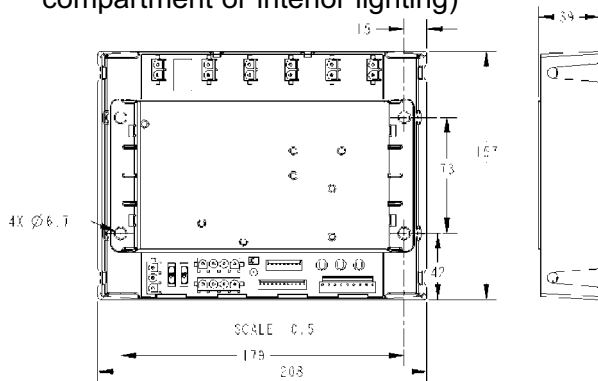

STANDARD

CARGO

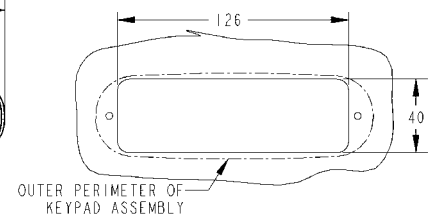
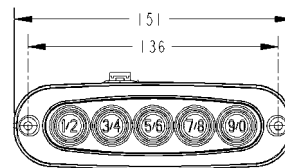
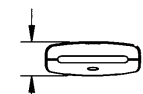
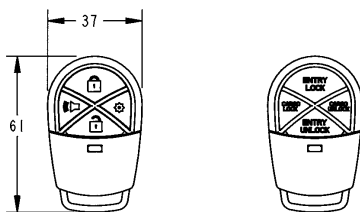

RECOMMENDED KEYPAD CLEARANCE CUTOUT

e-PAD

- Tactile, visual, and audio feedback
- Over 3000 code combinations with tamper lock-out feature
- Lighted keypad for more effective night time usage
- Vertical and horizontal orientations
- 5 user codes can be assigned
- Multiple layer code control
- Multiple keypads integration

e-FOB

- Reliable radio frequency (RF) transmission offers high security with code hopping technology and is FCC-Part 15 compliant
- 4-button standard fob (other configurations available)
- Customized graphics possible (buttons and logos)
- Can add up to 4 fob transmitters to vehicle

500-1100 e-FOB System

This cost-effective, simple, and integrated system offers increased security, convenience and functionality with reduced system installation and lower installation costs for demanding users of RV's, heavy trucks, emergency vehicles, agricultural and construction equipment.

Base system provides added convenience and security via a standard remote radio frequency (RF) transmitter providing automotive convenience to your vehicle.

FEATURES/BENEFITS:

- Increased end user convenience, operation is easy and intuitive
- Rugged and durable construction, is compliant to on-road, off-road, and industrial environmental requirements
- Increased vehicle security with multiple triggers and outputs
- Includes on-board locking and unlocking relays for up to 4 actuators
- Locking/unlocking confirmation
- Ignition controlled auto-locking
- Starter deactivation available for increased security
- High security with code hopping technology offers reliable radio frequency (RF) transmission and is FCC-Part 15 compliant

INSTALLATION:

- Standard 12 VDC power
- e-FOB receiver is easily installed with (2) #6 or M3 screws (not included) and can be mounted in a concealed location

AVAILABLE:

- Standard kit make up includes: 2 pre-trained RF remote fob transmitters, RF receiver, 14 wire harness, 10 wire harness, 2 wire harness, push button switch, and LED assembly key rings and manual
- Customized wire harnesses
- Customized graphics possible (buttons and logos - please inquire)
- Can add up to 4 fob transmitters to vehicle
- 3 different programming functions; standard mode, cargo mode and sustained mode.

Standard mode allows for the lock/unlocking of doors plus panic mode and one auxiliary output (controls lighting, opens compartment etc). Cargo mode allows for the lock/unlocking of main personnel doors plus independent control of many cargo/compartments doors. Sustained mode allows for the lock/unlocking of doors plus continuous output control with lower buttons pressing.

Patents Pending

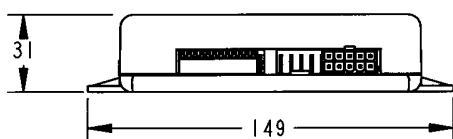
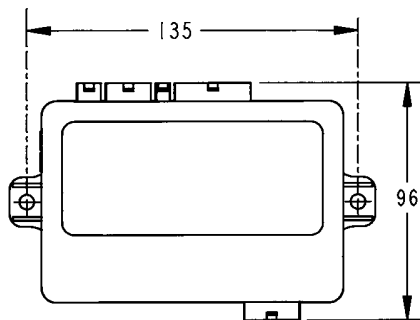

STANDARD

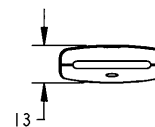
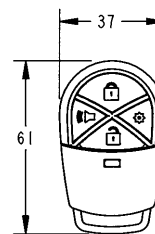

CARGO



Please refer to individual product codes and part drawings for complete dimensions, specifications, and installation procedures. Engineering assistance and application drawings are available.

For more information visit www.trimarkcorp.com

500-1200 e-PAD System

This integrated system offers increased security, convenience and functionality with reduced system installation complexity and lower installation costs for demanding users of RV's, heavy trucks, emergency vehicles, agricultural and construction equipment.

User friendly keypad system provides visual, audible and touch feedback. Keypad can be mounted horizontally, vertically, and with means to protect against vandalism and other tampering.

FEATURES/BENEFITS:

- Easy and intuitive to operate
- Rugged and durable construction, is compliant to on-road, off-road, and industrial environmental requirements
- I/O module with on-board locking and unlocking relays
- Can control up to 20 entry/compartments doors (expandable), uses staggered door control for minimized current draw
- Locking/unlocking confirmation
- Ignition controlled auto-locking
- Starter deactivation available for increased security
- Ability to provide 5 OEM definable functions from keypad, including ability to unlock one side of motor home baggage doors at a time
- 3 security system inputs (ability to sense entry door(s) and baggage door(s), and other security system devices such as glass break and motion detectors)
- 3 variable timed light activation output (porch, compartment or interior lighting)

This product is covered by one or more of the following:
 U.S. PATENT NO. 6,789,003
 U.S. PATENT NO. 7,034,655
 U.S. PATENT NO. 7,119,709
 DESIGN PATENT D486,376



AVAILABLE:

- Standard kit includes: Keypad, I/O module, gasket, push button switch, and LED assembly key rings and manual
- With e-FOB remote transmitter integration
- With security system integration
- Customized wire harnesses
- Multiplexed or discrete communications
- 2 different functions; standard and cargo modes. Standard mode allows for the lock/unlocking of doors plus panic mode and one auxiliary output (controls lighting, opens compartment etc.). Cargo mode allows for the lock/unlocking of main personnel doors plus independent control of many cargo/compartments doors.

INSTALLATION:

- Standard 12 VDC power
- Keypad is easy to install with (2) #8 or M4 flat head screws (not included)
- Keypad can be installed in a wide range of locations in door - either horizontal or vertical orientation
- I/O module is easily installed with (4) 1/4" or M6 screws (not included) and can be mounted in a concealed location

Please refer to individual product codes and part drawings for complete dimensions, specifications, and installation procedures. Engineering assistance and application drawings are available.

For more information visit www.trimarkcorp.com

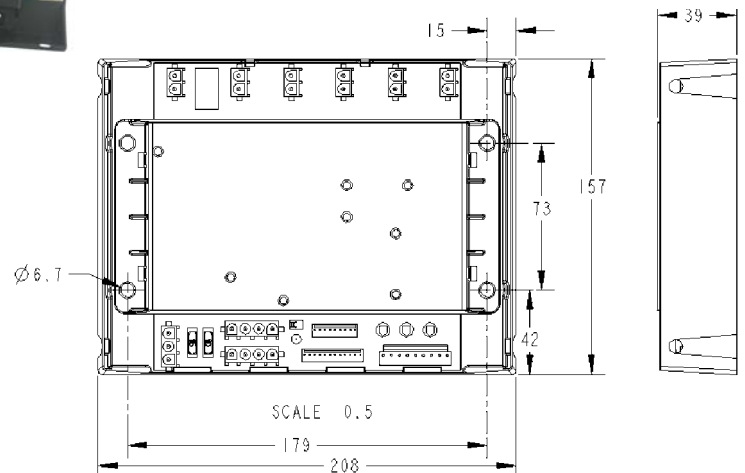
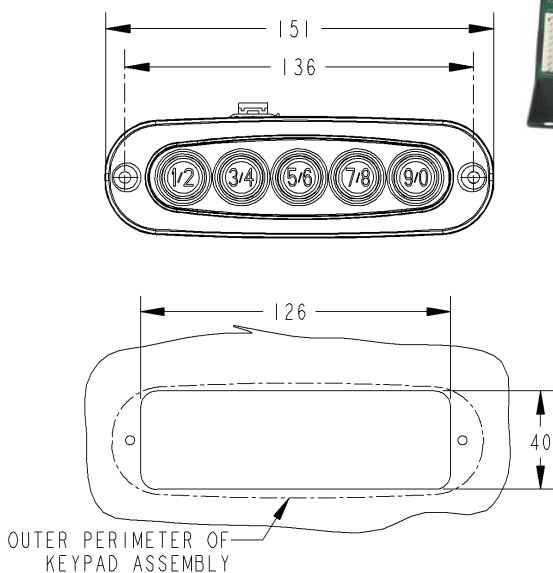

540-0100 e-PAD Keypad

This cost-effective, simple, and stand-alone system offers increased security, convenience and functionality with reduced system installation complexity and lower installation costs for demanding users of RVs, heavy trucks, emergency vehicles, agricultural and construction equipment.

User-friendly keypad system provides visual, audible and touch feedback. Keypad can be mounted horizontally, vertically, and with means to protect against vandalism and other tampering.

FEATURES/BENEFITS:

- Increased end user convenience, operation is easy and intuitive
- Rugged and durable construction, is compliant to on-road, off-road, and industrial environmental requirements
- Can control numerous entry/compartament doors
- Independent control of multiple door zones
- Tactile, visual, and audio feedback
- Over 3000 code combinations with tamper lock-out feature
- Lighted keypad for more effective night time usage
- Vertical and horizontal orientations
- 5 user codes can be assigned
- Multiple layer code control
- Discrete communications protocol
- Keypad controlled timed lighting output

AVAILABLE:

- With e-FOB remote transmitter integration
- Vertical and horizontal keypad
- Complete kit with wire harnesses and other accessories
- Customized wire harnesses

INSTALLATION:

- Keypad is easy to install with (2) #8 or M4 flat head screws (not included)
- Can be installed in a wide range of locations in door - either horizontal or vertical orientation
- Standard 12 VDC power

U.S. PATENT NO. 7,034,655
DESIGN PATENT D486,376

Please refer to individual product codes and part drawings for complete dimensions, specifications, and installation procedures. Engineering assistance and application drawings are available.

For more information, visit www.trimarkcorp.com

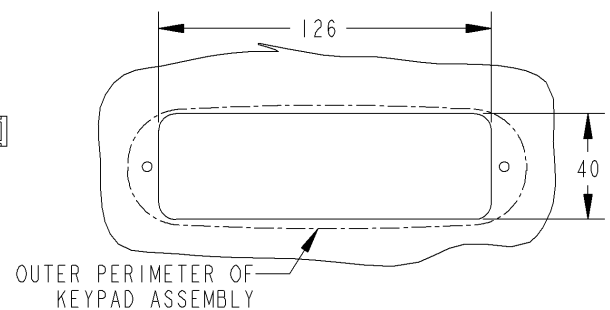
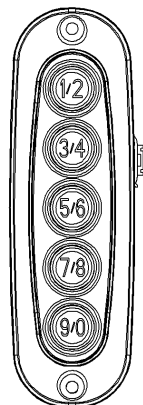
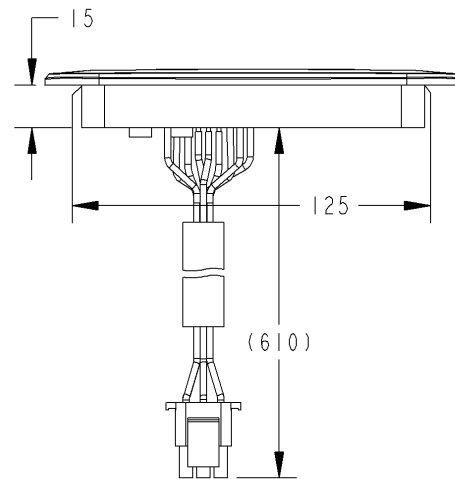
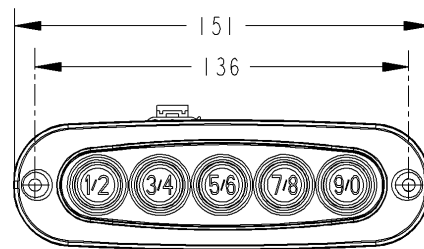

**RECOMMENDED KEYPAD
CLEARANCE CUTOUT**

550-0100 Power Lock Actuators

TriMark has several high quality power door lock actuators available with a variety of features and configurations. The actuators have been tested and validated to meet stringent requirements thus ensuring a long life of trouble free operation.

FEATURES/BENEFITS:

- High impact sealed case design
- Long travel distance - .83 to .86 inches (21-21.8mm)
- High output force for reliable locking, unlocking and power release functions
- Reliable and durable to high cycle counts in various environmental extremes
- Compact design allows for application in restricted space
- Compatible for use with TriMark power adaptable products
- Product selection options to ensure optimal fit for various applications
- Internal spring provides for extended or retracted rest position

INSTALLATION:

- TriMark power actuators are easy to install either by integrating mounting directly into available TriMark latches or paddle or with universal hardware parts that include fasteners, a zinc clamp, a mounting strap and a rod
- 12 volt supply



GUN STYLE

AVAILABLE:

- In a "gun style" with or without an overload protected motor
- In a compact, rectangular design with an overload protected motor, clutching mechanism for smooth operation and a rotatable/detachable tip
- With individual bullet style connectors or spade connector for ease of installation
- With 2 wires for power or 5 wires for power and actuator sensing
- Possible customization available to include special connectors, custom wire length and kitting options. Please contact TriMark for more information.
- In a power release design with high force output and optional internal return spring

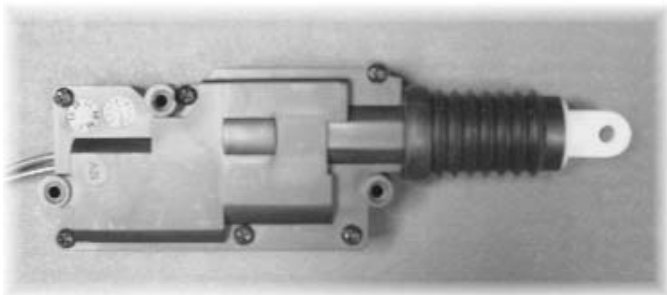

COMPACT STYLE



HIGH OUTPUT

Please refer to individual product codes and part drawings for complete dimensions, specifications, and installation procedures. Engineering assistance and application drawings are available.

For more information visit www.trimarkcorp.com

The following TriMark products are power lockable and are compatible with the e-ASK Systems. Please inquire about TriMark's ability to assist in the system design and product selection that is right for your requirements and needs.

Entrance Door Applications



Compartment and Baggage Door Applications



System kits are available and include handles, latches, remote transmitter FOB's and power lock actuators to provide a comprehensive access solution.

OPTIONS:

There are numerous options available to allow the e-ASK systems to provide extra value and functionality. Here is a partial listing of what's available:

- Optional kits can include: any wiring harnesses for all connection points of system, extra relays, switches, door contacts, actuators, mounting hardware, mounting brackets, door latches, and door paddle handles
- Customized wiring harnesses
- Additional fob transmitters and custom graphics
- Different programming functions allows for customized functionality with e-FOB or e-PAD outputs including standard mode, cargo mode or sustained mode
- Security system integration
- Multiplexed or discrete communications

ELECTRONIC ACCESSORIES:

The following are TriMark accessories that are available to assist you in completing your total system requirements. All of the accessories have been approved and are compatible with our e-ASK products, so you can be assured that they will perform and be trouble free for many years.

- 550-0200 Solenoid
- 590-0100 Wire Harnesses
- 590-0200 Door Contacts
- 590-0300 Relays
- 590-0400 Sirens
- 590-0500 Rocker Switches
- 590-0600 Plunger Switches
- 590-0800 Lighting
- 590-0900 Security Accessories

TriMark supplied or existing OEM security system components (e.g. motion detectors, door ajar detectors, glass break sensors, etc.)

Home / Sitemap User Password Login New User

Products Industries Services About Us Contact Us My Info Other TriMark Sites

NEW PRODUCT
540-0200 e-GRAB System

- ▶ Lighted keypad and handle rod
- ▶ Option door bell feature
- ▶ High quality polished chrome plating is durable and stylish
- ▶ Integrated product allows for easy installation

▶ Other New Products...

Products

- Latches
- Handles
- Linkages
- Electronics
- Hinges

Industries

- ▶ Off-Highway
- ▶ Recreational Vehicle
- ▶ Specialty Vehicle
- ▶ On-Highway Truck
- ▶ Industrial Enclosure/Cabinets

Quick Links

- ▶ RoHS Compliance **NEW!**
- ▶ Sample Request
- ▶ Global Contacts
- ▶ Literature Request

Other TriMark Sites

- ▶ TriMark Europe
- ▶ TriMark Service and Replacement
- ▶ TriMark Customer Extranet
- ▶ Suppliers

For additional information and new product introductions relating to TriMark's Mechanical/Electrical/Electronic solutions, please refer to the website --

www.trimarkcorp.com



500 Bailey Avenue • P.O. Box 350 • New Hampton, IA 50659

Tel: 641-394-3188 • Fax: 641-394-2392

Email: trimark@trimarkcorp.com • www.trimarkcorp.com

Cedar Court • Walker Road • Bardon Hill

Coalville, UK LE18 4ZH

Tel: +44 (0) 1530 512460 • Fax: +44 (0) 1530 512461

Email: sales@trimarkeu.com • www.trimarkeu.com

TriMark Service & Replacement Parts

510 Bailey Avenue • P.O. Box 350 • New Hampton, IA 50659

Toll Free: 1-800-461-8616 • Email: trimarkparts@trimarkcorp.com