

## **e-ASK Keyless-entry System Installation and Instruction Manual OEM / Dealer / Installer Cargo Lock/Unlock Version**

This manual provides the necessary information for the proper installation and use of TriMark's **e-ASK** system. Included in this comprehensive access, security, keyless-entry system are the following elements:

- **e-FOB:** keyless entry radio frequency [RF] remote FOB transmitter and receiver
- **e-PAD:** Convenient keypad user interface
- **e-ASK:** I/O module

The following illustrations are provided to properly identify the contents of this system.

### **e-FOB with RF receiver, 2 remote transmitters FOBs, and wiring harnesses**



### **e-PAD keypad**



(Note: Horizontal or Vertical e-PADs are available)

### **e-ASK I/O module**

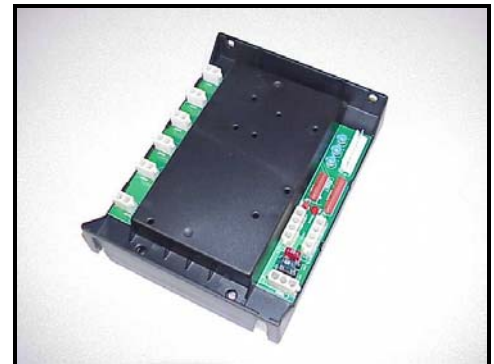

**Table of Contents:**

**e-FOB** Operation and Features..... Page 2  
**e-PAD** Operation and Features..... Page 3  
**e-ASK** I/O Module Operation and Features ..... Page 5  
Mounting **e-ASK** Components..... Page 8  
Wiring Color Code Tables and Diagrams ..... Page 9  
Teaching Additional Transmitter FOBs..... Page 13  
Teaching Keypad New Authority/Access Codes ..... Page 14  
Troubleshooting..... Page 16

**e-FOB Operation and Features**

The FOB transmitter and receiver are shipped programmed. After making all necessary wiring connections (see pages 9-12), the **e-FOB** system will function as indicated below. Only the entry unlock function of the **e-FOB** remains while the engine is running - other functions are deactivated. Both the Entry Lock and Cargo Lock must be pressed to arm the alarm system. Press the Entry or Cargo Unlock button to disarm the system and deactivate the alarm mode.

- **Entry Lock:** Locks all entry doors and arms security system.
- **Entry Unlock:** Unlocks entry doors and disarms security system. Also activates the porch light.
- **Cargo Lock:** Locks all compartment doors and arms security system.
- **Cargo Unlock:** Unlocks all compartment doors and disarms security system. Also activates the compartment lighting.

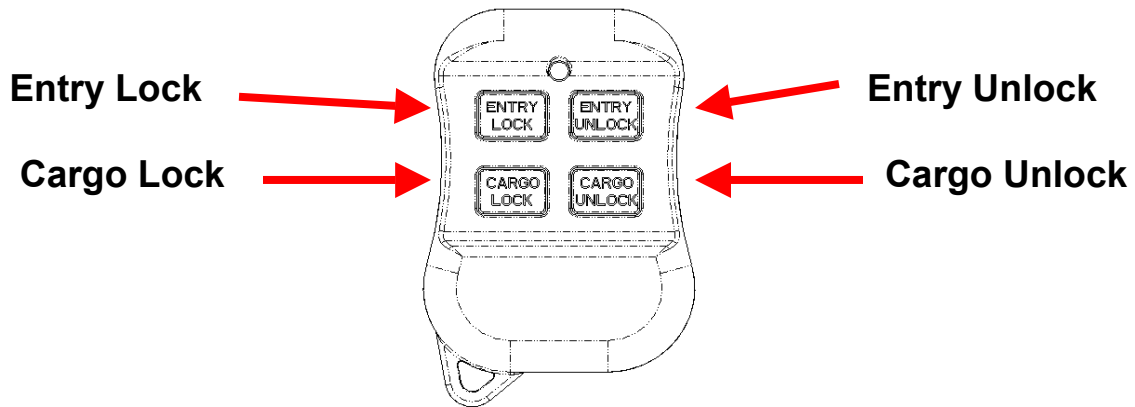

## **e-PAD Operation and Features**

The **e-PAD** is shipped with default Authority and Access codes. When all necessary wiring connections are made, the **e-PAD** system will function as indicated below. Unless the OEM or dealer has changed default codes, the Authority and Access codes are as follows:

Access code:

Digit 1	Digit 2	Digit 3	Digit 4	Digit 5
1 / 2	3 / 4	5 / 6	7 / 8	9 / 0

Authority code:

Digit 1	Digit 2	Digit 3	Digit 4	Digit 5
7 / 8	7 / 8	7 / 8	7 / 8	7 / 8

### **Locking doors with keypad:**

Regardless of the configuration of the system, **e-PAD** locking operation (lock all doors) is accomplished by pressing and holding down the first button (1 / 2) for 1-2 seconds. An access code is not needed to lock the doors.

### **Unlocking doors with keypad and other secure operations:**

After access codes have been assigned secure **e-PAD** operations can be accomplished by enabling the keypad. The keypad is enabled by entering a valid 5-digit access code. After entering an access code, the keypad is enabled for 5 seconds and a sixth button press initiates a secure operation, such as door unlocking or other operations. Entering the correct access code alone will not initiate a secure operation.

The following sequence illustrates how to perform secure operations with **e-PAD**.

- Enter a valid 5-digit access code (see default access code information above and page 15). Confirmation beeps indicate the system is enabled.
- Press the (3 / 4) button within 5 seconds and all doors will unlock.

If an unassigned button or no button is pressed while the system is enabled, the keypad reverts back to disabled state.

The **e-ASK** system can be configured in 1 of 4 ways, as defined by #1 and #2 DIP Switch settings on I/O module (see page 4 for **e-PAD** configuration information). The secure keypad operations are set depending on system configuration.

### **e-PAD Configurations:**

SECURE OPERATIONS ARE DEPENDENT ON SYSTEM CONFIGURATION. After entering the access code, one must press a 6<sup>th</sup> digit to unlock specific doors or perform an operation according to the following listing.

#### **6<sup>th</sup> Button Press Operation**

- Configuration A [SW 1 off / SW 2 off]:
  - Button (1/2): Unassigned
  - Button (3/4): Unlocks all entry and compartment doors
  - Button (5/6): Unassigned
  - Button (7/8): Activates zone 6 unidirectional actuation
  - Button (9/0): Toggles Aux 1 output
  
- Configuration B [SW 1 off / SW 2 on]:
  - Button (1/2): Unlocks all entry door(s)
  - Button (3/4): Unlocks all entry and compartment doors
  - Button (5/6): Unassigned
  - Button (7/8): Activates zone 6 unidirectional actuation
  - Button (9/0): Toggles Aux 1 output
  
- Configuration C [SW 1 on / SW 2 off]:
  - Button (1/2): Unlocks all entry doors
  - Button (3/4): Unlocks all doors assigned to relay bank A
  - Button (5/6): Unlocks all doors assigned to relay bank B
  - Button (7/8): Unlocks all doors assigned to relay bank C
  - Button (9/0): Unlocks all doors assigned to relay bank D
  
- Configuration D [SW 1 on / SW 2 on]:
  - Button (1/2): Unlocks all entry doors
  - Button (3/4): Unlocks all entry and compartment doors
  - Button (5/6): Unlocks all curb side compartment doors (relay banks C-D)
  - Button (7/8): Unlocks all driver side compartment doors (relay banks A-B)
  - Button (9/0): Toggles Aux 1 output

See the table on page 6 for S2 DIP switch assignments.

### **e-PAD / e-FOB Dome/Porch Light Activation:**

The dome/porch light is activated for a timed duration (5-60 seconds) whenever a keypad button is pressed or when system is unlocked from FOB transmitter or vehicle switch. The time duration is dependent on the trim pot A setting (see page 6). The dome/porch light is deactivated with starting the engine.

### **e-PAD Protective Deactivating Security Feature:**

After repeated entry of incorrect codes (20 button presses without enabling), the keypad is deactivated for 1 minute. This helps prevent unauthorized access by entering random codes. No beep will sound with button press while the system is disabled.

### **e-PAD Backlighting Power Management Feature:**

In order to provide continuous backlighting, but not drain the vehicle battery, the **e-PAD** deactivates backlighting if battery voltage is low. If voltage is below 11 volts, then continuous backlighting is shutoff until the battery is fully charged. When continuous backlighting is off, the keypad still “wakes” up when a button is pressed. In this case, the backlighting is activated for only two minutes.

### **e-ASK I/O Module Operation and Features**

The following vehicle switch assignments of connector J2 (see page 11), pins 1 thru 6 define system configuration. These are the I/O module outputs that correspond to the 6<sup>th</sup> button press operations. When a pin is grounded, its corresponding function is specified.

- Configuration A [SW 1 off / SW 2 off]
  - Pin 1: Locks all doors
  - Pin 2: Unlocks all doors
  - Pin 3: Unassigned
  - Pin 4: Unassigned
  - Pin 5: Unassigned
  - Pin 6: Unassigned
  
- Configuration B [SW 1 off / SW 2 on]
  - Pin 1: Locks all doors
  - Pin 2: Unlocks all doors
  - Pin 3: Locks all compartment doors (banks A-D, not entry door relays)
  - Pin 4: Unlocks all compartment doors (banks A-D, not entry door relays)
  - Pin 5: Locks entry door(s)
  - Pin 6: Unlocks entry door(s)
  
- Configuration C [SW 1 on / SW 2 off]
  - Pin 1: Locks all doors
  - Pin 2: Unlocks entry door(s)
  - Pin 3: Unlocks bank A compartment(s)
  - Pin 4: Unlocks bank B compartment(s)
  - Pin 5: Unlocks bank C compartment(s)
  - Pin 6: Unlocks bank D compartment(s)
  
- Configuration D [SW 1 on / SW 2 on]
  - Pin 1: Locks all doors
  - Pin 2: Unlocks all doors
  - Pin 3: Unlocks curb-side compartment doors (banks C-D)
  - Pin 4: Unlocks driver-side compartment doors (banks A-B)
  - Pin 5: Locks entry door(s)
  - Pin 6: Unlocks entry door(s)

### Trim Pot Variable Resistors (diagram on page 11):

These trim pots provide adjustable settings for timed outputs. Clock-wise rotation increases activation time. Trim pot A (R31) is assigned to dome/porch light activation (5-60 second range). Trim pot B (R32) is assigned to Auxiliary 1 output (0.5-5.0 minute range) and trim pot C (R33) is assigned to Auxiliary 2 compartment lighting output (0.5-5.0 minute range). Trim pot settings are updated every 30 seconds. Trim pot adjustments may not be observed immediately.

### S2 DIP Switches:

The S2 DIP switch is located under the I/O module cover. Functional assignments are described below.

- Switches 1 and 2 provide a functional assignment of how relay banks A-D are grouped. The following table shows the DIP switch assignment, configuration type (A-D), and subsequent relay assignment. Configuration D is standard.

Configuration	Switch 1	Switch 2	Relay bank grouping
A	Off	Off	1 group exists. All banks are grouped with entry door.
B	Off	On	2 groups exist. #1 entry group. #2 group to banks A, B, C, and D.
C	On	Off	5 groups exist. # 1 entry. #2 to bank A. #3 to bank B. #4 to bank C. #5 to bank D.
D	On	On	3 groups exist. #1 entry group. #2 group to banks A and B. #3 group to banks C and D.

- Switch 3 provides the ability to deactivate auto locking and unlocking via engine running input.
  - Switch 3 ON: auto locking and unlocking activated.
  - Switch 3 OFF: auto locking and unlocking deactivated.
- Switch 4 provides the ability to designate the functionality of the Cargo Lock and Cargo Unlock buttons. Switch 4 ON is standard position.
  - Switch 4 ON: buttons lock and unlock compartment doors
  - Switch 4 OFF: the Cargo Lock button initiates the panic function. The Cargo Unlock button toggles the Auxiliary 1 output on/off. (See page 7)

### S1 Learn Switch Connector:

The Learn Switch Connector is used to reset the keypad to assign a new authority code. See pages 11 and 14 for further information on teaching keypad a new authority code.

### Status LED (diagram on page 11):

LED flashes at power-up and provides short periodic pulses if voltage supply is low.

### Miscellaneous I/O Module Features:

**Door locking and unlocking**—A short single pulse output provides locking operation and 2 short pulse outputs provide unlocking operation. The locking and unlocking pulses have opposite polarities. Locking and unlocking operations are activated via vehicle switch inputs or according to **e-PAD** and **e-FOB** instructions above.

### Locking and unlocking confirmation–

- After locking either the entry door or compartment doors from **e-FOB** transmitter, the headlights flash once and the siren sounds once. When the entry door and compartment doors are both locked within one minute, the headlights flash and siren sounds twice.
- Locking and unlocking confirmation is deactivated while engine is running.
- Confirmation may be shut off (see page 8).

**Door Ajar Confirmation** – A triple siren chirp sounds if any compartment or entry door is open when the entry and compartment doors are locked. If a door is open, the alarm is not armed.

The following table describes audio/visual activations at various conditions.

Outputs	Single Lock confirmation	All Lock confirmation	Alarm
Siren	Not used	Not used	1 minute or when shut off
Horn	1 chirp	2 chirps	Not used
Headlights	1 flash	2 flashes	1 minute or when shut off

**Deactivate Lock Confirmation** – The system defaults to confirmation ON with power-up. Horn and headlight confirmation can be toggled off and on from the keypad.

1. Enter valid access code.
2. Hold down (9 / 0) button until double beep sounds. Release.
3. Press (1 / 2) button.

**Unidirectional actuation pulse output (door opening, battery disconnect, etc.)**– The J14 connector (Zone 6) actuation output provides a short pulse when it is activated via a vehicle switch, keypad (depends on system configuration), or FOB transmitter (depends on I/O module DIP switch #4 setting). This short pulse output is prohibited while the engine is running.

**Panic mode**–(Not a standard function) Available when DIP Switch 4 is ON. Pressing and holding the Cargo Lock Button of the **e-FOB** transmitter for 2 seconds activates panic mode. During panic mode, siren is continuously activated and headlights flash for a maximum of 1 minute. Unlocking the vehicle via the FOB transmitter deactivates panic mode. Compartment door control is eliminated while in panic mode.

**Alarm mode**–After locking entry and compartment doors, the system is armed. The alarm is activated when entry door or compartment doors are opened, or by grounding the extra security input. The extra security input could be connected to external shock sensing, motion detection or other sensing device. When alarm is triggered, the siren is continuously activated and headlights flash for 1 minute. Unlocking doors via FOB transmitter, keypad, interior switch or starting the engine deactivates alarm mode.

**Timed dome/porch light activation**–The dome/porch light is activated upon pressing any keypad button or by unlocking entry door via FOB transmitter. The activation duration is controlled via trim pot A (see page 6). Starting the engine deactivates the light.

**Compartment light activation**– Compartment lights are activated upon unlocking compartment doors (bank A-D) or toggling vehicle switch. The activation duration is controlled via trim pot C (see page 6). Starting the engine deactivates the light.

**Automatic locking and unlocking** –When S2 DIP switch # 3 is ON auto-locking feature is activated. All doors are locked after the engine has been running for 5 seconds. Doors unlock when the engine is turned off. To deactivate this feature, move switch 3 to OFF. The alarm is not enabled/disabled by automatic locking/unlocking.

## Mounting e-ASK Components

Contact TriMark for specific mounting details, such as drawings, placement suggestions, mounting hardware, etc.

### **General Mounting Guidelines:**

- The RF receiver should be placed in an interior location that does not shield RF signals. You may need to try multiple locations to optimize reception. The antennae must be left fully extended and exposed. Minimize shielding from metal enclosures.
- Top surface of the I/O modules has features that can be self-tapped with a #8-32 fastener. Fasteners should not be longer than 0.5 inches in thread length. These features can be used to mount the RF receiver to the I/O module. Also other components, wiring holders, etc. can be mounted with these features.

### **RF Receiver Module**

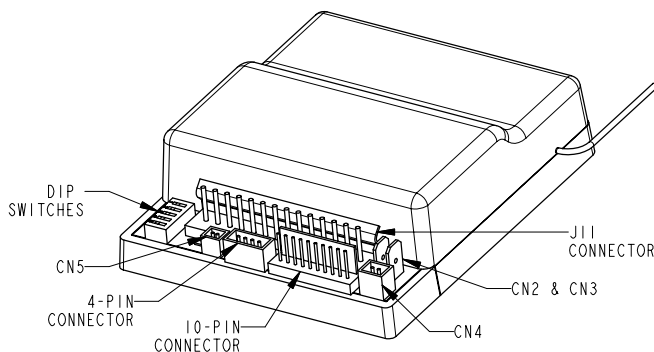

### **I/O Module**

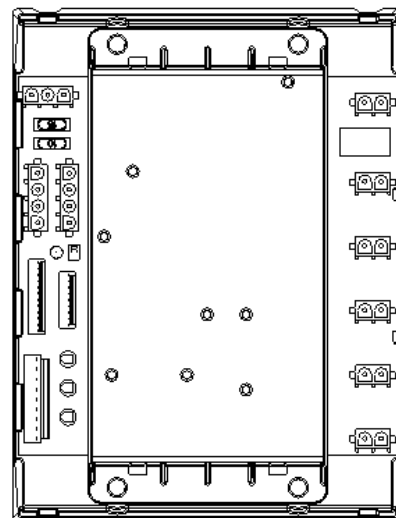

**Wiring color code tables and diagrams**--The following tables and diagrams are provided to show color-coded wire and pin assignments for the **e-ASK** system.

**TABLE 1: RF RECEIVER ASSIGNMENTS**

<b>WIRE COLORS</b>	<b>J11 – 14-PIN HARNESS</b>	
PURPLE / WHITE	CARGO UNLOCK BUTTON INPUT/OUTPUT. BUILT-IN RELAY, 12A.	1
PURPLE / WHITE		2
WHITE / GREEN	LOCK OUTPUT (N/C RELAY 30)	3
WHITE / BLACK	LOCK INPUT (N/C RELAY 87A)	4
YELLOW	CONNECT FOR TEACH REMOTE FOB	5
BLACK	GROUND	6
BROWN	UNASSIGNED	7
RED	+12 VDC POWER SOURCE.	8
BLUE / WHITE	UNLOCK INPUT (N/C RELAY 87 A)	9
WHITE / RED	UNLOCK OUTPUT (N/C RELAY 30)	10
PINK / BLACK	LOCK / UNLOCK POLARITY (N/O RELAY 87)	11
WHITE	UNASSIGNED	12
PINK	UNASSIGNED.	13
PINK	UNASSIGNED	14
<b>WIRE COLORS</b>	<b>10-PIN HARNESS</b>	
ORANGE	UNASSIGNED	1
WHITE / BROWN	UNASSIGNED	2
BROWN / WHITE	CARGO LOCK AUX.	3
WHITE / YELLOW	UNASSIGNED	4
GRAY	UNASSIGNED	5
PURPLE / GREEN	UNASSIGNED	6
WHITE / BLUE	UNASSIGNED	7
BLUE	UNASSIGNED	8
GREEN	UNASSIGNED	9
PURPLE	UNASSIGNED	10
<b>WIRE COLORS</b>	<b>4-PIN HARNESS</b>	
WHITE / RED	UNLOCK INPUT FROM INTERIOR SWITCH	2
WHITE / GREEN	LOCK INPUT FROM INTERIOR SWITCH	4
<b>0.250 MALE CONNECTORS</b>		
CN2 & CN3	BUILT-IN STARTER KILL RELAY. NON-POLARIZED. 40A	
<b>* DO NOT USE A TEST LIGHT ON THE MODULE'S 500mA OUTPUTS</b>		

**TABLE 2: LOCK, UNLOCK, AND DOOR ACTUATE RELAY OUTPUT CONNECTIONS**



J9 CONNECTOR: Unidirectional Actuation Output (E.G. Door Opening Or Battery Disconnect)



J10 CONNECTOR: Lock/Unlock Bank D



J8 CONNECTOR: Lock/Unlock Bank C



J7 CONNECTOR: Lock/Unlock Bank B



J5 CONNECTOR: Lock/Unlock Bank A

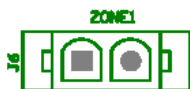

J6 CONNECTOR: Lock/Unlock Zone 1 (Entry)

With the exception of Zone 6 output, each of the above relay banks provide positive and negative current flow for typical motorized actuators. The relay banks are rated for 25 amps and thus the cumulative (sum of all actuators) current flow should be less than 25 amps. Zone 1 is designated as an entry door output while the remaining banks are undesignated. These can be use for secure access of occupant doors, specialized compartment, baggage doors, or miscellaneous doors. See page 6 for further information on S2 DIP switch settings. The Zone 6 output is unidirectional and is intended for an actuating operation, such as opening the hood, gas cap door, or disconnecting the battery. Contact TriMark for further technical assistance and to ensure that actuators and relay assignments are appropriate. Correct installation will promote better reliability of the system.

**TABLE 3: OTHER VEHICLE CONNECTIONS ON I/O BOARD**

TRIMPOT A— Sets Timed Dome/Porch Light Output (CW Increases Duration)

TRIMPOT B—Sets Timed Aux 1 output (CW Increases Duration)

TRIMPOT C—Sets Timed Aux 2 Compartment Light Output (CW Increases Duration)

J11 INPUTS: Inputs For RF Receiver And Vehicle Status— Pin Assignments:

- PIN 9: Power/Ground (connect to +12 or ground, depends if pins 7 and 8 are sinks or sources)
- PIN 8: Engine Running
- PIN 7: Key Inserted
- PIN 6: Panic Mode From RF Receiver
- PIN 5: \* Button from RF Receiver
- PIN 4: Unlock from RF Receiver
- PIN 3: Lock from RF Receiver
- PIN 2: +12 VDC to RF Receiver
- PIN 1: Ground to RF Receiver

S1 LEARN INPUT: Input To Reset Keypad Codes

D19 STATUS LED

J3 AND J4 TriNet: Keypad Connectors

- PIN 4: TriNet B
- PIN 3: TriNet A
- PIN 2: Ground
- PIN 1: +12 Volts

J1 CONNECTOR: Connect to a Reliable Power Source.  
 PIN 3: GND  
 PIN 2: GND  
 PIN 1: +12 V

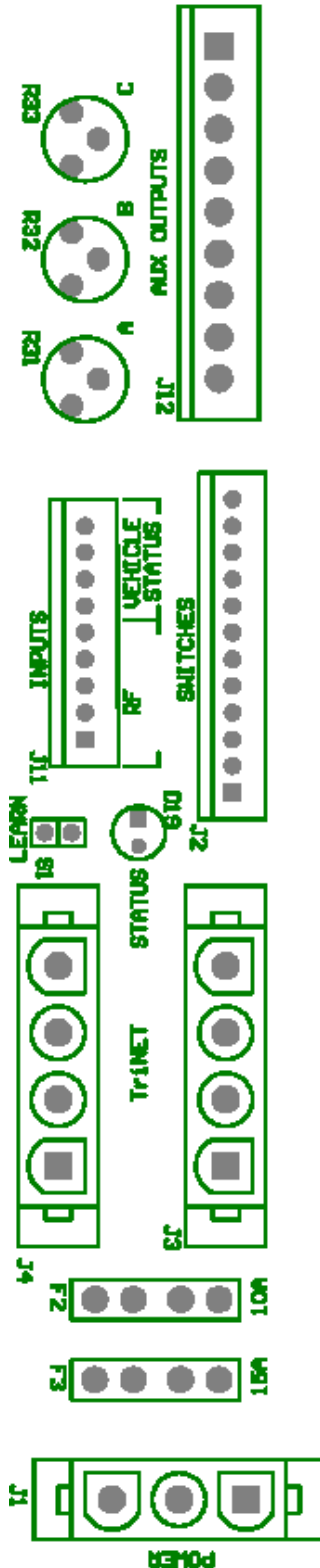

J12 AUX OUTPUT: Relay Driver Outputs - Pin Assignments

- PIN 1: +12 v
- PIN 2: Horn
- PIN 3: Headlight Or Marker Lights
- PIN 4: Interior Light / Porch light
- PIN 5: Auxiliary 1
- PIN 6: Auxiliary 2-Compartment Lights
- PIN 7: Entry Door Ajar
- PIN 8: Compartment Door Ajar
- PIN 9: Siren

NOTE: Pins 2-9 Sink To Ground Upon Activation. Pin 1 To Be Used As (+12 V) Opposite Side Of Relay Coil.

J2 SWITCH: (connect to ground to activate) Pin Assignments:

- PIN 12: Security System
- PIN 11: Compartment Door Ajar
- PIN 10: Entry Door Ajar
- PIN 9: Auxiliary 2 Toggle
- PIN 8: Auxiliary 1 Toggle
- PIN 7: Actuate Zone 6
- PIN 6: Depends On Dip Switch Config.
- PIN 5: Depends On Dip Switch Config.
- PIN 4: Depends On Dip Switch Config.
- PIN 3: Depends On Dip Switch Config.
- PIN 2: Depends On Dip Switch Config.
- PIN 1: Depends On Dip Switch Config.

NOTE: PINS 1-6 Provide Different Locking And Unlocking Functions. Their Relay Bank Assignment Depends On S2 DIP Switch Setting. The Connection Of Both Pin 8 (Aux 1 Toggle) And Pin 7 (Actuate Zone 6) Is Not Recommended.

F2: RED 10-amp fuse protects Trinet Communications (Power And Communication) to the keypad.

F3: BLUE 15-amp fuse protects the power actuator outputs of the I/O module.

**DIAGRAM 1: WIRING UP ACTUATORS TO I/O MODULE**

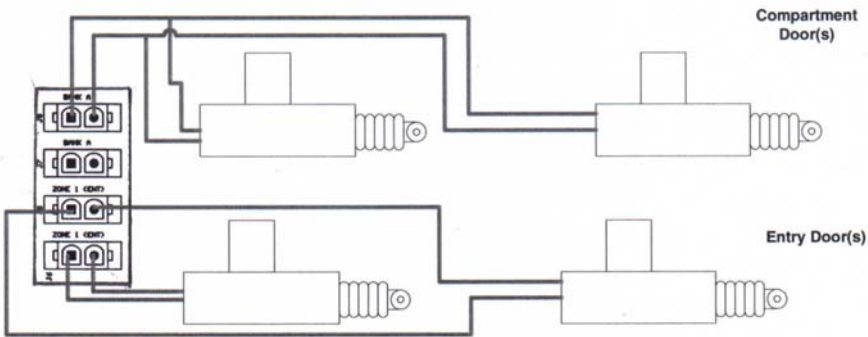

The cumulative current draw of actuators at each relay bank should not exceed 25-amp rating.

**DIAGRAM 2: AUXILIARY OUTPUTS WIRING**

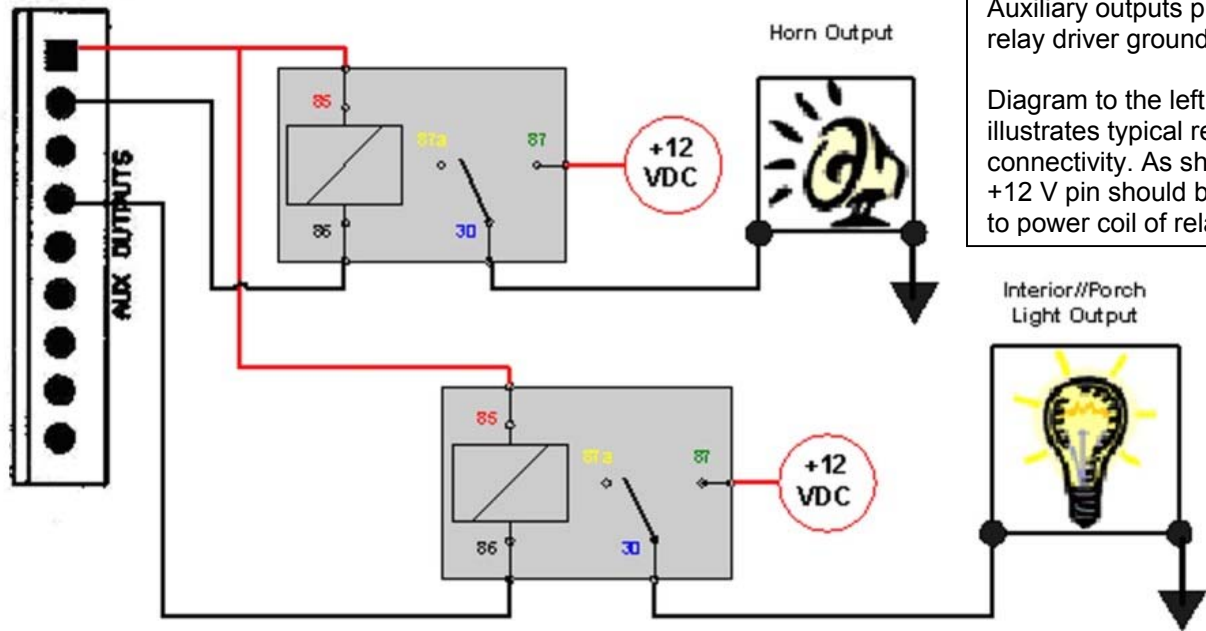

Auxiliary outputs provide relay driver ground signal. Diagram to the left illustrates typical relay connectivity. As shown, +12 V pin should be used to power coil of relays.

**DIAGRAM 3: SWITCH INPUTS WIRING**

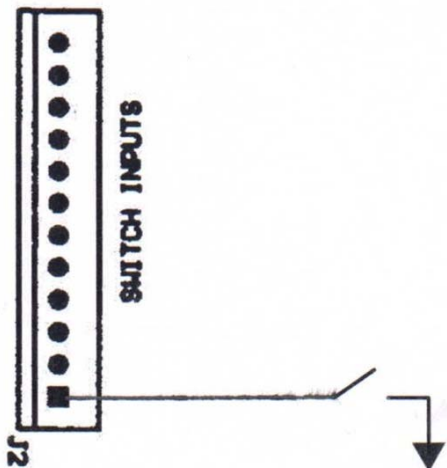

Switch inputs are activated when sunk to ground. Diagram to the left illustrates typical switch connectivity.

## Teaching Additional Transmitter Fobs

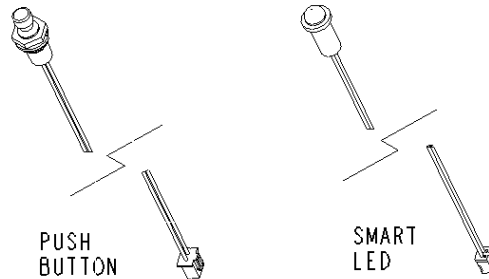
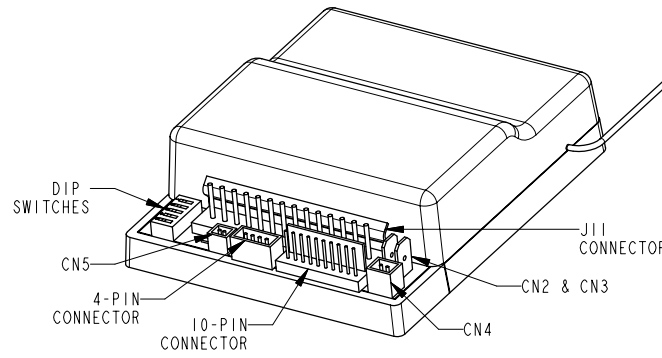

1. Plug the smart LED into CN4 and the push button into CN5.
2. Connect the yellow wire with spade connector to +12 V (see red wire with spade connector).
3. Press and hold the push button switch until the LED assembly turns on and then off (about 5 seconds).
4. Press the Entry Lock button of each new FOB transmitter once. Up to 4 transmitters may be programmed at one time.
5. When done, disconnect the yellow wire and verify proper e-FOB transmitter and receiver reception.

### NOTES:

- If you place the system in learn mode and teach nothing, the system will exit in 10 seconds.
- If the 4-transmitter limit is exceeded, the system erases the earliest trained transmitter. To erase a lost remote, teach the remaining or new remotes a total of 4 times.
- It is recommended to teach all transmitters to be used at the same time. This eliminates the potential to erase an earlier trained transmitter.
- The memory for codes is NON VOLATILE and will not be erased if power is removed.

# Teaching Keypad New Authority / Access Codes

Three steps to programming new Authority Code:

1. Reset the keypad to default state.
2. Assign a new authority code. The authority code is used to define access codes.
3. Assign new access codes. The access code enables the system for secure operations. Up to 5 access codes can be assigned.

The memory for codes is NON VOLATILE and will not be erased if power is removed.

## **1. Reset keypad to default state:**

- a. Cycle (short then open) the S1 pins of I/O module learn connector (see page 11).
- b. Hold the (9 / 0) button for 10 seconds until keypad quits beeping.

This resets the keypad to a default state and erases any previous authority and access codes.

## **2. Assign new authority code:**

- a. Press the (5 / 6) button for 5 seconds – the keypad will beep.
- b. Enter the default code.
  - (1 / 2) first button
  - (1 / 2) first button
  - (5 / 6) middle button
  - (9 / 0) last button
  - (9 / 0) last button
- c. Enter a new 5-digit authority code. Keypad will provide confirmation beeps when 5-digit authority code has been entered.
- d. Re-enter your new 5-digit authority code. Keypad will provide confirmation beeps, and revert back to its default operation mode.

The authority code is to be controlled by individuals (owners of vehicle, fleet manager, etc.) who manage the distribution of access codes to vehicle users. The authority code should be changed when the vehicle is sold. The following area can be used to document the authority code. The authority code does not enable secure functions (lock/unlock doors, etc.). The authority code is only used to assign access codes.

Authority Code				
Digit 1	Digit 2	Digit 3	Digit 4	Digit 5

### 3. Assign new access codes:

With a valid authority code (see page 3 or 14), an access code can be programmed with the following instructions.



- a. Press the (5 / 6) button for 5 seconds, the keypad will beep. The backlighting LED of the keypad will flash indicating the learn mode.
- b. Enter in the 5-digit authority code (see page 3 or 14). Keypad will provide two confirmation beeps.
- c. Press and release the button that corresponds to the access number. For example, press (1 / 2) button for access #1 and press (3 / 4) button for access #2. During this activity you are defining 1 of 5 access numbers. A subsequent code will be assigned to this access #. The keypad will provide a confirmation beep after this single button press.
- d. Enter in your new 5-digit access code. The keypad will provide confirmation beeps.
- e. Re-enter new access code. The keypad will provide confirmation beeps.

Repeat process to assign additional access codes.

Up to 5 different access codes can be assigned at one time. As additional access codes are defined, pre-existing access codes are over-written. For example, if a new access code is assigned for access #3, the previous access #3 code is no longer valid. The following table can be used to document the access code assignment.

Access #	User Name	Digit 1	Digit 2	Digit 3	Digit 4	Digit 5
1						
2						
3						
4						
5						

# Troubleshooting

Problem Description	Possible Solution
<b>e-FOB Hints</b>	
Button press does not provide correct operation	Verify power to the I/O module and RF receiver
	Re-teach the FOB transmitter to the receiver. Ensure that only Lock button is pressed while in learn mode.
No operation or intermittent operation	Mount RF receiver away from enclosed metal areas and fully extend antennae
	Check FOB transmitter battery voltage. Batteries need to be changed every 1-2 years depending on usage.
Alarm mode starts when powered up	Press unlock button of FOB transmitter
One particular <b>e-FOB</b> function does not work.	Check wire connection of affected function at RF module, wiring harness, and I/O module.
Zone 6 activated inadvertently	Verify that Zone 6 is not connected to the  button on the FOB transmitter. The  button can activate both outputs.
<b>e-PAD Hints</b>	
No response with button press	Verify power to the I/O module; check fuse.
	Verify that keypad cable is connected. (rest of system will function)
Access code is not recognized	Verify that code has not been changed. Reassign keypad with instructions on pages 14-15
	Confirm use of an access code, not the authority code.
Continuous keypad backlighting is off until a button is pressed.	Vehicle battery voltage has dropped below 11 V.
Unexpected, secure operation occurs	Verify DIP switches are set to correct configuration setting.
<b>e-ASK I/O Hints</b>	
No response in any system element	Verify power to the I/O module; check fuse.
Lights and panic mode do not turn off with ignition start.	Verify that connector J11, pins 7, 8 and 9 are wired properly.
Output relay latches on or off.	Verify that power to relay comes from connector J12, pin 1.
	Cycle power to system. If condition continues, replace relay.