

e-ASK

electronic Access Security Keyless-entry

e-FOB / e-PAD Installation Instructions

FCC ID: TV2EFOB1

(UM17 ~ 22271-03)



500 Bailey Avenue
P.O. Box 350
New Hampton, Iowa 50659 U.S.A.
Tel: 641-394-3188
Fax: 641-394-2392
www.trimarkcorp.com

Table of Contents

Introduction	1
e-PAD Operation and Features - Standard.....	2
e-PAD Operation and Features - Cargo	3
Non-doorbell e-PAD Operation and Features	3
Doorbell e-PAD Operation and Features	4
Lock Doors With Keypad.....	4
Secure Operations	4
6th Button Press Operation - Standard Mode	4
6th Button Press Operation - Cargo Mode.....	4
Protective Deactivating Security Feature	5
Buzzer Operation	5
Grab Handle Lighting	5
Doorbell	5
Dome Light Activation	5
Emergency Override	5
Teaching Additional FOB Transmitters	6
Teaching Keypad New Authority / Access Codes.....	7
Assign New Access Codes.....	8
Smart LED:	8
Dip Switch Setting Assignment.....	9
DIP Switch #1: Cargo/Standard Mode	10
DIP Switch #2: Sustained Output	10
DIP Switch #3: Unassigned	10
DIP Switch #4: Unassigned	10
DIP Switch #5: Headlights Supervision	10
DIP Switch #6: Arm Alarm.....	10

DIP Switch #7: Automatic Lock/Unlock.....	11
DIP Switch #8: Keypad #5 Output and FOB Long Unlock.....	11
DIP Switch #9: Keypad #5 Output and FOB Long Unlock.....	11
DIP Switch #10: 3rd Unlock/Staggered Lock.....	11
Additional System Features	11
Light Activation	11
2nd Unlock Output	12
3rd Unlock Output	12
2nd Auxiliary Output.....	12
Panic Mode	12
Lock/Unlock Confirmation	12
Starter Kill Feature	12
Vehicle Alarm	12
Lock/Unlock Confirmation Control.....	13
Training Wireless Switches	13
Troubleshooting	14
Appendix: Installation and Mounting e-FOB System.....	I
General Mounting Guidelines:.....	I
Wiring Color Code Tables and Diagrams.....	I
Mating Connector Information.....	I
RF Receiver	II
Wiring Connections	IV

Introduction

This manual provides the necessary information for the proper installation and use of TriMark's Discrete **e-PAD / e-FOB** System.

The Discrete **e-PAD / e-FOB** system includes:

- **e-FOB** (keyless entry radio frequency [RF] FOB transmitter and receiver)
- **e-PAD** or **e-GRAB Handle** (keypad user interface) - Keypad integrated grab handle. ***Clean acrylic rod with mild soap and water only.***

The receiver and FOB transmitters are shipped programmed. After making all necessary wiring connections (see appendix page IV), the **e-PAD / e-FOB** system will function as indicated in this manual.

RF Controller



Keypad — available vertical or horizontal



e-GRAB Handle



e-FOB Operation and Features - Standard Mode

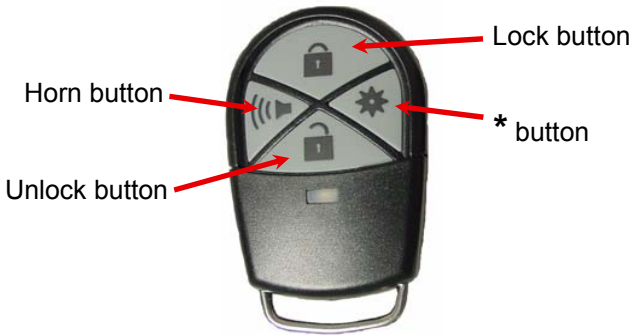

Button	Function
Lock	Locks all doors and arms security system.
Unlock	Unlocks doors and disarms security system. Also activates the dome light.
Horn button	Activates panic mode when pressed and held for 2 seconds.
* button	* button function is OEM/dealer defined. Possible assignment include: interior/exterior lighting, awning extension/retraction, gas cap, hood, etc.

Notes:

- While the engine is running only the unlock function of the **e-FOB** remains activated — other functions are deactivated.
- For information on changing the default configuration, see DIP Switch Setting Assignment on page 9.

e-FOB Operation and Features - Cargo Mode

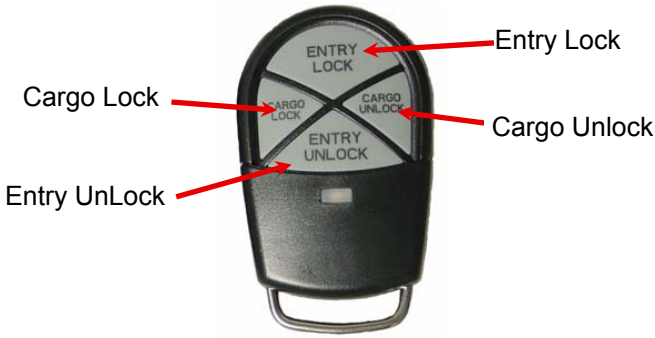

Button	Function
Entry Lock	Locks entry doors and arms security system.
Entry Unlock	Unlocks entry doors and disarms security system. Also activates the porch light.
Cargo Lock	Locks compartment doors and arms security system.
Cargo Unlock	Unlocks compartment doors and disarms security system.

Notes:

- While the engine is running only the entry unlock function of the **e-FOB** remains activated —other functions are deactivated.
- For information on changing the default configuration, see DIP Switch Setting Assignment on page 9.

Non-doorbell e-PAD Operation and Features

The **e-PAD** is shipped with default authority and access codes. Unless the OEM or dealer has changed default codes, the authority and access codes are as follows:

Access code:

Digit 1	Digit 2	Digit 3	Digit 4	Digit 5
1 / 2	3 / 4	5 / 6	7 / 8	9 / 0

Authority code:

Digit 1	Digit 2	Digit 3	Digit 4	Digit 5
7 / 8	7 / 8	7 / 8	7 / 8	7 / 8

Doorbell e-PAD Operation and Features

Access code:

Digit 1	Digit 2	Digit 3	Digit 4	Digit 5
1	2	3	4	4

Authority code:

Digit 1	Digit 2	Digit 3	Digit 4	Digit 5
4	4	4	4	4

Lock Doors With Keypad

Press and hold down the (1 / 2) or (1) button for 1-2 seconds. An access code is not needed to lock the doors.

Secure Operations

Entering a valid 5-digit access code enables secure operations. After entering an access code, the keypad is enabled for 5 seconds and a 6th button press initiates a secure operation, such as unlocking the doors.

Notes:

- The authority code does not allow for secure operations. It is only used to assign access codes (see page 8 for information on setting authority and access codes).
- If an unassigned button or no button is pressed while the system is enabled, the keypad reverts back to disabled state.

6th Button Press - Standard Mode

Button (1 / 2) or (1): Unlock entry doors.

Button (3 / 4) or (2): Unlock doors wired to 2nd Unlock output.

Button (5 / 6) or (3): Unlock doors wired to 3rd Unlock output.

Button (7 / 8) or (4): Sequentially activate entry unlock, 2nd unlock and 3rd unlock outputs.

Button (9 / 0): Toggle dome light output.

6th Button Press - Cargo Mode

Button (1 / 2) or (1): Unlock entry doors.

Button (3 / 4) or (2): Unlock doors wired to 2nd Unlock output.

Button (5 / 6) or (3): NA

Button (7 / 8) or (4): Entry and 2nd unlock.

Button (9 / 0): Toggle dome light output.

Protective Deactivating Security Feature

If a correct code is not entered after 20 button presses, the keypad enters an inactive mode that disables button recognition for 1 minute. This helps prevent unauthorized access by entering random codes. There is no button feedback while the system is disabled.

Buzzer Operation

The keypad buzzer chirps once when power is first applied to the keypad and for each key press during regular use. When an authorized access code is entered, the system chirps twice to indicate readiness to unlock doors.

The keypad chirps twice for each button press while in learn mode. When a new access code is defined, the system chirps 3 times. If an incorrect code is entered during learn mode, there is a 1-2 second chirp.

Grab Handle Lighting

The grab handle is lit continuously. The **e-PAD** is lit with a button press and while training new access and authority codes.

Doorbell

The doorbell button provides a 0.5 second ground pulse from the 2nd Auxiliary output when pressed. An access code is not necessary for the doorbell. DIP Switch #8 and #9 of the RF receiver must be OFF to provide the correct output.

Dome Light Activation

The dome light is toggled on for 5 minutes with a secure (9 / 0) operation. Repeating the (9 / 0) operation while the dome light is on will turn the light off.

Emergency Override

To disarm the alarm in case of FOB transmitter and access code loss:

1. Turn ignition on (apply 12V to yellow wire).
2. Press and hold the push button for 3 seconds.
3. Turn ignition off (remove 12V from yellow wire).

Teaching Additional FOB Transmitters

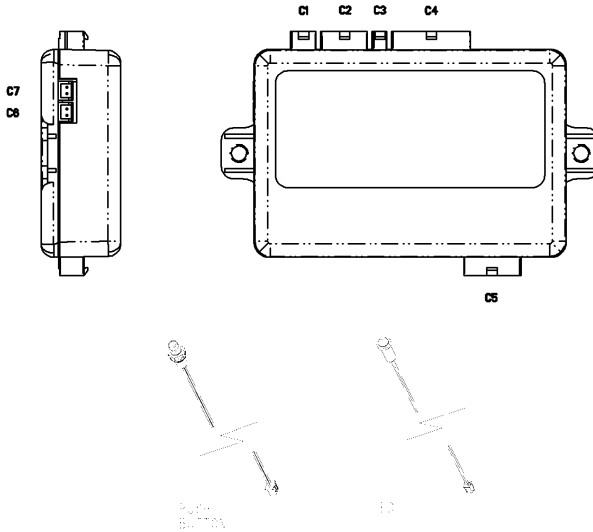

1. Plug the LED into C6 and the push button into C7 on the receiver.
2. Turn ignition off and disarm alarm.
3. Press and release the programming button 3 times. The LED will turn on after 3 seconds.
4. Press and release the Lock button of each new FOB transmitter once. The LED will flash off and the horn and siren will sound once. Up to 60 transmitters may be programmed at one time.

Notes:

- If you place the system in learn mode and teach nothing, the system will exit in 10 seconds.
- When new transmitters are taught, all old transmitters are erased.
- The memory for codes will not be erased if power is removed.
- As soon as the LED turns off, the system is fully functional.

Teaching Keypad New Authority / Access Codes

The following procedure assigns an authority and access code. The 5-digit access code is assigned to position one. The same 5-digit code is assigned to the authority and access codes. If the attempt to assign new codes fails, previous authority and access codes remain active.

1. Plug the LED into C6 and the push button into C7 on the receiver.
2. Turn ignition on (12V at yellow wire of C1) and disarm alarm.
3. Press and release the programming button 3 times. Wait 3 seconds. The keypad will beep for 5 seconds.
4. Enter a 5-digit code. (Double chirps after each button press). The keypad chirps 3 times after the 5-digit entry.
5. Re-enter new code for confirmation. The keypad will chirp four times after successful confirmation. A long beep indicates failure to change codes.
6. Confirm the new access code.

The user is given 2 minutes to complete this procedure. If it isn't completed in time, or an error is made, the system will exit learn mode and a long chirp will sound to indicate the error.

Important: Authority and access codes should not be the same. If someone figures out an access code and discovers it to be an authority code as well, they can create their own access code and gain entrance to your vehicle.

Notes:

- The authority code is to be controlled by individuals (owners of vehicle, fleet manager, etc.) who manage the distribution of access codes to vehicle users.
- The authority code should be changed when the vehicle is sold.
- The authority code does not enable secure functions (lock/unlock doors, etc.)—it is only used to assign access codes.
- Doorbell systems only allow codes using buttons 1-4 and provides for 4 unique access codes.

The following area can be used to document the authority code:

Authority Code				
Digit 1	Digit 2	Digit 3	Digit 4	Digit 5

Assign New Access Codes

With a valid authority code, an access code can be programmed with the following instructions.

1. Press the (5 / 6) or (3) button for 5 seconds, the keypad will beep. The backlighting LED of the keypad will flash indicating the learn mode.
2. Enter in the 5-digit authority code (see above or page 3 for the code). Keypad will provide a long beep that will stop after you have defined an access number.
3. Press and release the button that corresponds to the access number. For example, press (1 / 2) or (1) button for access #1 and press (3 / 4) or (2) button for access #2. During this activity you are defining 1 of 5 (4) access numbers. A subsequent code will be assigned to this access #. The keypad will provide a confirmation beep after this single button press.
4. Enter in your new 5-digit access code. The keypad will provide confirmation beeps.
5. Re-enter new access code. The keypad will provide confirmation beeps.

Repeat process to assign additional access codes.

Note: Up to 5 (4) different access codes can be assigned at one time. As additional access codes are defined, pre-existing access codes are overwritten. For example, if a new access code is assigned for access #3, the previous access #3 code is no longer valid.

The following area can be used to document the access code assignments.

Access #	User Name	Digit 1	Digit 2	Digit 3	Digit 4	Digit 5
1						
2						
3						
4						
5						

Smart LED:

The smart LED indicates system status:

- Slow flash = Armed
- Off = Disarmed
- Fast flash = Alarm activated

DIP Switch Setting Assignment

The DIP Switch settings control additional functions. Power to the receiver should be disconnected and reconnected after a DIP switch is changed. Functional assignments are described below:

Switch	DIP Switch Settings		
#1	Standard vs Cargo Mode	ON = Cargo Mode	OFF = Std.Mode
#2	Left & Right Buttons Output	ON = Sustained	OFF = Pulse
#3	--	--	--
#4	--	--	--
#5	Headlights Supervision	ON = 0.25 sec. Pulse	OFF = 30 sec.
#6	Arm Alarm	ON = 1 Lock Button Press	OFF = 2 lock button presses
#7	Automatic Lock/Unlock	ON = Enabled	OFF = disabled
#8	Keypad #5 output and FOB long unlock	ON = Lights output for 5 minutes	OFF = aux. 2 output for 5 minutes
#9	Keypad #5 Output and FOB long unlock	ON = Output 0.25 sec. pulse	OFF = output on for 5 minutes
#10	3rd Unlock/Staggered Lock	ON = staggered with lock	OFF = activated with unlock

DIP Switch #1: Cargo/Standard Mode

- DIP switch #1 ON: pressing the Cargo Lock button pulses the staggered lock output. A Cargo Unlock button press provides pulses from Auxiliary and 2nd unlock outputs.
- DIP switch #1 OFF: the Horn button (center left) activates panic mode. Horn, siren, lights, parking lights activate for 30 seconds.

DIP Switch #2: Sustained Output

- DIP switch #2 ON: the middle left and right buttons provide sustained outputs. Output lasts as long as the button is pressed –up to 30 seconds. Middle left button activates horn output. Middle right button activates auxiliary output. DIP switch #1 must be OFF.
- DIP Switch #2 OFF: see DIP switch #1 for output.

DIP Switch #3: Unassigned

DIP Switch #4: Unassigned

DIP Switch #5: Headlights Supervision

- DIP switch #5 ON: the headlights flash once on an unlock command.
- DIP switch #5 OFF: the headlights are activated with the dome lights. Lights remain illuminated for 30 seconds with an unlock command. Arming the alarm or starting the car deactivates the lights immediately.

DIP Switch #6: Arm Alarm

- DIP switch #6 ON: a single lock press locks doors and arms alarm.
- DIP switch #6 OFF: first lock press locks doors. Second lock press arms alarm.

DIP Switch #7: Automatic Lock/Unlock

- DIP switch #7 ON: the auto-locking feature is activated. All doors are locked 5-seconds after ignition start. Doors unlock when the ignition is turned off. THIS FEATURE IS CANCELED if a door is open when the ignition is started. This protects against accidental locking of keys in the vehicle.
- DIP switch #7 OFF: Automatic lock/unlock feature is disabled.

DIP Switch #8: Keypad #5 Output and FOB Long Unlock

- DIP switch #8 ON: the #5 keypad output provides a mirrored output to the headlights.
- DIP switch #8 OFF: the #5 keypad output provides a mirrored output to Aux 2.

DIP Switch #9: Keypad #5 Output and FOB Long Unlock

- DIP switch #9 ON: the keypad #5 output provides a 3 second pulse and FOB long unlock provides a 0.5 second pulse output dependent upon DIP switch #8.
- DIP switch #9 OFF: the keypad #5 output provides a pulse (0.5 second) and FOB long unlock provides a 5 minute output dependent upon DIP switch #8.

DIP Switch #10: 3rd Unlock/Staggered Lock

- DIP switch #10 ON: the 3rd unlock output is staggered to the lock actuation to decrease peak current draw.
- DIP switch #10 OFF: the 3rd unlock output actuates with an unlock command.

Additional System Features

Light Activation

When the alarm is armed, the parking lights flash and horn honks. With an unlock instruction from either the FOB transmitter or keypad; the dome light stays illuminated for 30 seconds. The headlight actuation is controlled by DIP Switch #5 with an unlock instruction. (With lock the headlights pulse once.)

2nd Unlock Output

Press and release the Unlock button on the FOB transmitter twice for a pulse output. Enter secure operation #2 from keypad in standard mode. In cargo mode, the 2nd unlock output occurs with a cargo unlock button press.

3rd Unlock Output

The 3rd unlock output is actuated with the unlock command and with the secure operation #3. If DIP switch #10 is on, the 3rd unlock is staggered to the lock output. The secure operation #3 continues to provide a pulse. In cargo mode, staggered lock occurs with a cargo lock button press.

2nd Auxiliary Output

The 2nd Auxiliary output is actuated by pressing the doorbell button on the keypad or holding down the unlock button for 2 seconds. The output is either a pulse output or a 5-minute toggle dependent on DIP switch #9. This is the doorbell feature on the doorbell keypad.

Panic Mode

Pressing and holding the Horn button (center left) for 2 seconds activates panic mode. During panic mode, horn/siren is continuously activated and headlights and parking lights flash for 30 seconds. Pressing the Lock or Unlock button deactivates panic mode.

Lock/Unlock Confirmation

The horn and siren chirp once when the alarm is armed. If the alarm has been set off since the last unlock command, the siren and horn chirp 4 times to indicate the alarm activity when the system is disarmed. The horn and siren chirp twice on unlock. The headlight and parking light outputs pulse once on a lock and unlock.

Starter Kill Feature

The starter kill feature is active for 30 minutes after the alarm is activated. Install a relay controlled by the starter kill feature between the ignition key switch and starter solenoid.

Vehicle Alarm

The alarm is armed when the doors are locked per DIP switch #6. When the alarm is armed, the parking lights flash and the horn/siren chirp. The smart LED flashes continuously.

The alarm is activated with a security trigger input or if the ignition is started. The horn, siren, parking lights and head lights flash for 30 seconds. The starter kill is activated for 30 minutes. Press the Lock or Unlock buttons to deactivate the alarm.

There is a 5 second delay before the system will recognize a security input. If a security input (door ajar switch, motion sensor, glass break sensor, etc.) is triggered while the alarm is armed, the security input must be turned off and then on before the alarm is activated. The horn and siren chirp 3 times if a security input is active when the alarm is armed.

Lock/Unlock Confirmation Control

The siren and horn confirmation is controlled by pressing lock, unlock, and auxiliary (*) buttons at the same time. A single chirp is heard when confirmation is muted. A double chirp occurs when turned on.

Cargo mode: entry lock, entry unlock, cargo unlock.

Training Wireless Switches

Up to 20 wireless switches can be trained to the RF controller. A wireless switch can provide door ajar information, input from a shock sensor, a motion sensor, a glass break sensor, etc.

1. Plug the LED into C6 and the programming button into C7 on the receiver.
2. Turn ignition off and disarm alarm.
3. Press and release the programming button 5 times. The LED will turn on green after 2 seconds.
4. Press the programming button X number of times to store the wireless sensor in X position (1-25). The LED will briefly flash red.
5. Remove the magnet from the wireless sensor to activate the output. The horn will honk and the siren will sound.
6. Repeat steps 4 and 5 to train additional wireless sensors. If two sensors are trained to the same position, only the second sensor will be active.
 - As soon as the LED turns off, the system is fully functional.
 - The system exits learn mode after 10 seconds of inactivity.
 - To erase all wireless sensors, turn ignition on and press the programming button 10 times. The horn and siren will sound once to indicate that all sensors have been erased.
 - The memory for codes will not be erased if power is removed.

Troubleshooting

Problem Description	Possible Solution
e-FOB Hints	
Button press does not provide correct operation	Verify power to RF receiver
	Replace FOB transmitter battery
	Re-teach the FOB transmitter to the receiver
No operation or intermittent operation	Mount RF receiver away from enclosed metal areas and fully extend antenna
	Check FOB transmitter battery voltage. Batteries need to be changed every 1-2 years depending on usage.
One particular e-FOB function does not work	Check wire connection of affected function at RF module and wiring harness
e-PAD Hints	
No response with button press	Verify connection of keypad.
Access code is not recognized	Verify that code has not been changed. Reassign keypad with instructions on page 8.
	Confirm use of an access code, not the authority code.
Acrylic rod develops surface cracks	A petroleum or alcohol based product was used to clean rod. Only use mild soap and water on rod.

This product has been manufactured with methods to ensure high quality and to meet the high expectations of our customers. *TriMark* warrants this product to be free from workmanship defects and will remedy issues per *TriMark's* warranty policy.

Remote transmitter FOBs, batteries, and other equipment subject to normal wear and deterioration may need to be replaced periodically by dealer and/or end user and are not covered by this warranty. *TriMark* will not be liable for indirect, special, incidental or consequential damages.

This system complies with part 15 of the FCC Rules. Operation is subject to the following two conditions:

- (1) This device may not cause harmful interference and
- (2) This device must accept any interference received including interference that may cause undesired operation.

Note: The manufacturer is not responsible for any radio or television interference caused by unauthorized modifications to this equipment. Such modifications could void the user's authority to operate the equipment.

Appendix: Installation and Mounting e-FOB System

Contact TriMark for specific mounting details, such as drawings, placement suggestions, mounting hardware, etc.

General Mounting Guidelines:

The RF receiver should be placed in an interior location that does not shield RF signals. You may need to try multiple locations to optimize reception. The antennae must be left fully extended and exposed. Minimize shielding from metal enclosures.

Mount **e-PAD** grab handle to vehicle with #8 or M4 screws. Connect 12V to the LED with the red wire to +12V and black wire to ground. Keypad harness provides connection between discrete keypad and RF controller.

Wiring Color Code Tables and Diagrams

The following tables and diagrams are provided to show color-coded wire and pin assignments for the **e-FOB** system. Connect all wires before plugging module into wiring harness.

Mating Connector Information

C1	Power input:	Amp 106527-4 (4-pin)
C2	Keypad input:	Amp 106527-8 (8-pin)
C3	Lock/Unlock input:	Amp 106527-2 (2-pin)
C4	Non-relay output:	Amp 1-106527-4 (14-pin)
C5	Relay output:	Amp 1-106527-0 (10-pin)

Terminals: Amp 106529-2 for 18-22 AWG wire
 Amp 794418-1 for 16 AWG wire



RF Receiver

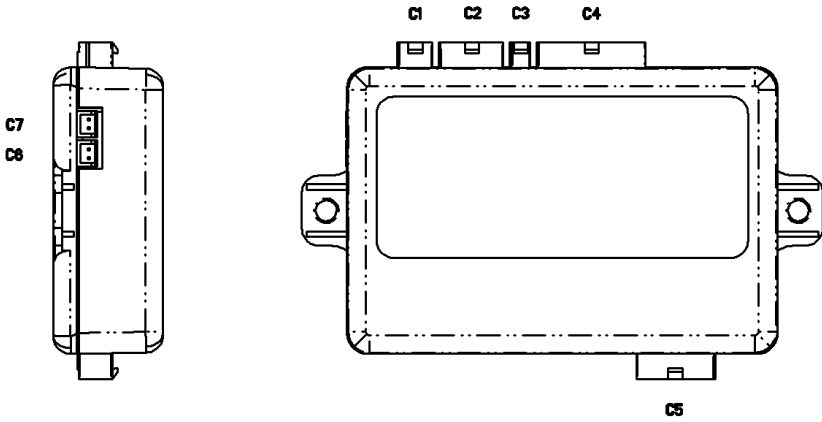

Wire Colors	CONNECTOR 1: 4-PIN HARNESS	
--	--	1
Yellow	Ignition Input	2
Black	Ground Input	3
Red	Power (+12V)	4
Wire Colors	CONNECTOR 2: KEYPAD HARNESS	
Integrated Harness		
Wire Colors	CONNECTOR 3: 2-PIN HARNESS	
Green/White	Lock Input (-)	1
Blue/White	Unlock Input (-)	2

Wire Colors	CONNECTOR 4: 14-PIN HARNESS	
White/Purple	(-) Security Trigger Input 3	1
Orange	Armed Output (-500 mA)	2
Brown	Starter Kill Output (-500 mA)	3
Gray	Lights Output (-500 mA)	4
Brown/White	Horn Output (-500 mA)	5
White/Black	(-) Security Trigger Input 1	6
White/Yellow	Siren Output (A/C)	7
Red/White	Aux. 2 Output (-500 mA)	8
Black /White	Aux. Output (relay 15A)	9
White/Orange	2nd Unlock Output (-500 mA)	10
White/Blue	3rd Unlock/Staggered Lock (-500mA)	11
White	Parking Lights (relay 15A)	12
White/Red	(+)Security Trigger Input 2	13
Light Green	Siren Output (A/C)	14
Wire Colors	CONNECTOR 5: 10-PIN HARNESS	
Green/Black	Door Lock (N/C) (relay 30A)	1
--	--	2
Purple	Dome Light Output (relay 15A)	3
Pink	Dome Light (N/O) (relay 15A)	4
Pink/Black	Dome Light (N/C) (relay 15A)	5
Green/White	Door Lock (N/O) (relay 30A)	6
Green	Lock Output (relay 30A)	7
Blue/Black	Door Unlock (N/C) (relay 30A)	8
Blue/White	Door Unlock (N/O) (relay 30A)	9
Blue	Unlock Output (relay 30A)	10

* DO NOT USE A TEST LIGHT ON THE MODULE'S 500MA OUTPUTS



Wiring Connections

WIRING CONNECTION - LOCK/UNLOCK

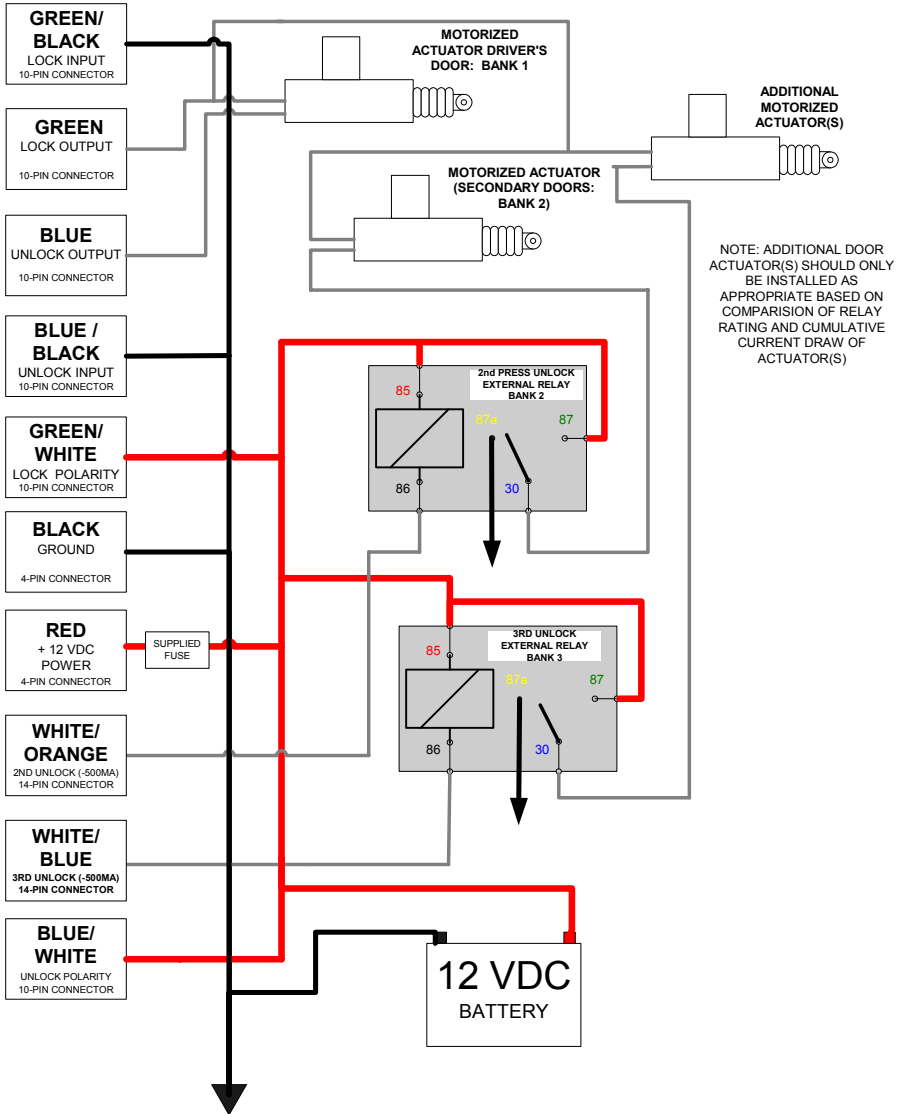

ACCESSORY CONNECTIONS

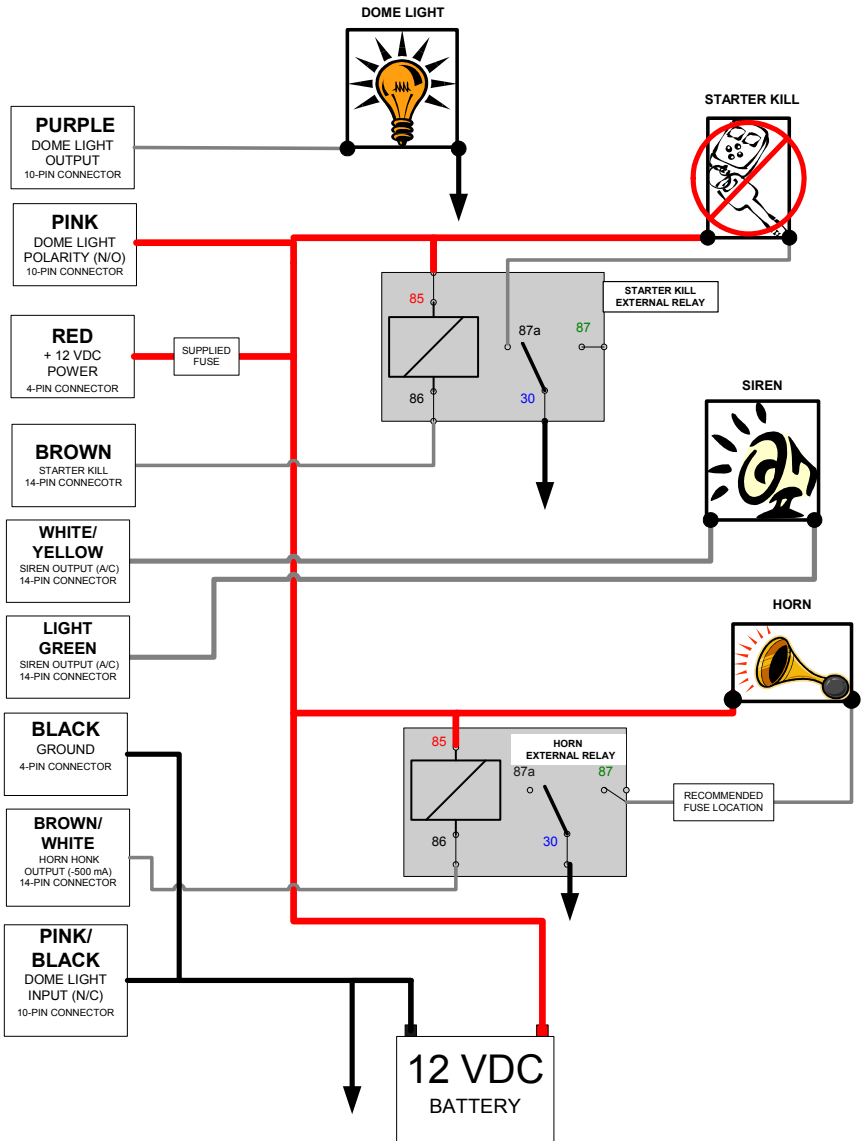



500 Bailey Avenue
P.O. Box 350
New Hampton, Iowa 50659 U.S.A.
Tel: 641-394-3188
Fax: 641-394-2392
www.trimarkcorp.com

UM17
22271-03
12/07-2