

030-0200
Paddle Handle
030-0250 With
Inside Release Lever



This flush paddle was designed for heavy-duty off-highway vehicle entrance doors and features robust construction and pivot plate versatility

DESIGNED FOR:

- Off-highway vehicle applications - construction, mining, agricultural, forestry
- Doors requiring latch location remote from activating handle
- Door thickness of 2" (50.8mm) or greater



TriMark Corporation
500 Bailey Avenue
P.O. Box 350
New Hampton, Iowa 50659
United States
Tel: 641-394-3188
Fax: 641-394-2392
1-800-447-0343
www.trimarkcorp.com



TriMark Europe
Cedar Court
Walker Road
Bardon Hill
Coalville LE67 1TU
United Kingdom
Tel: +44(0)1530 512460
Fax: +44(0)1530 512461
www.trimarkeu.com



AVAILABLE:

- In right or left hand configurations (left hand shown)
- In locking or non-locking configurations

MATERIAL:

- Housing and paddle: die cast zinc alloy
- Pivot components: zinc plated, mild steel

FINISH:

- Housing and paddle: black powder coated
- Copper-nickel-chrome plated

INSTALLATION:

- Four 10-24 UNC or M5 X .8 mounting screws (not included)
- See illustrated door cut-out detail (opposite page)

NOTE: Mounting bosses are tapped 3/8" deep

CAUTION: Paddle does not comply with locking requirements of FMVSS 206.

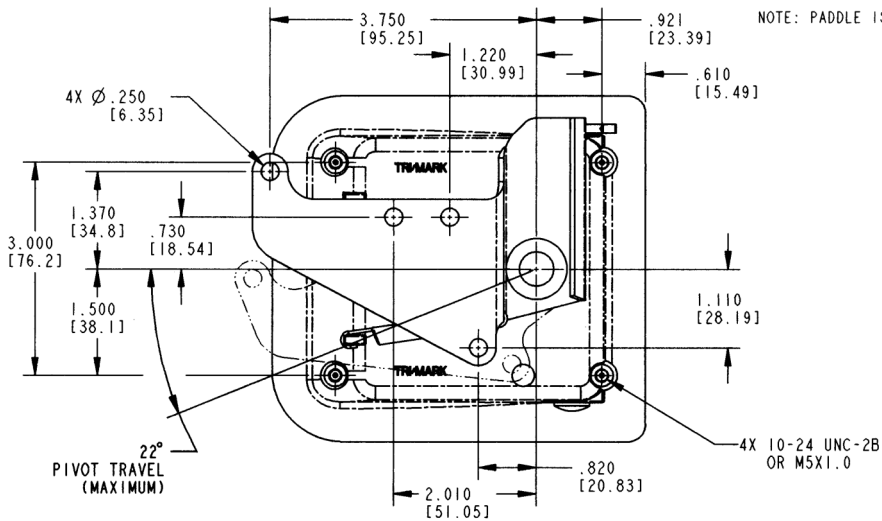

NOTE: PADDLE IS RIGID IN LOCKED POSITION

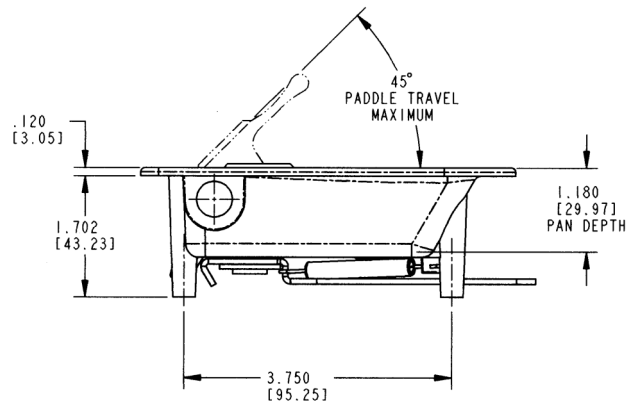
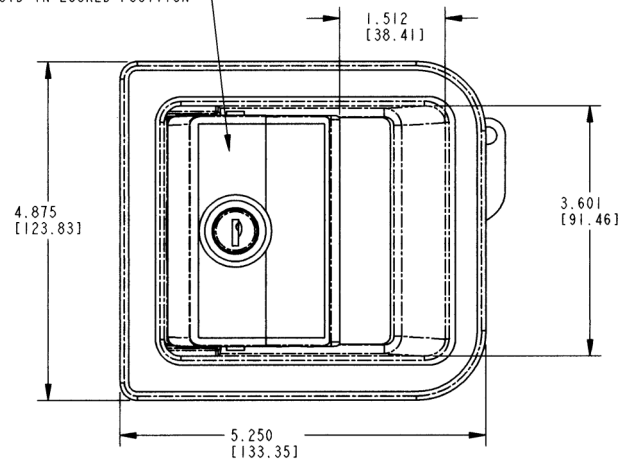

For more information visit
www.trimarkcorp.com

030-0250 Paddle Handle With Inside Release Lever

The 030-0250 Paddle Handle incorporates the basic material and concepts used in the 030-0200 Paddle Handle.

- Inside release lever eliminates much of the linkage typically required with conventional inside handles
- Operator can exit even if the door is locked from the outside
- Optional pivot plates available for your particular application
- Nylon paddle axle bushing and pivot plate thrust washers

