

# 050-0250 Single Rotor Latch & Linkage

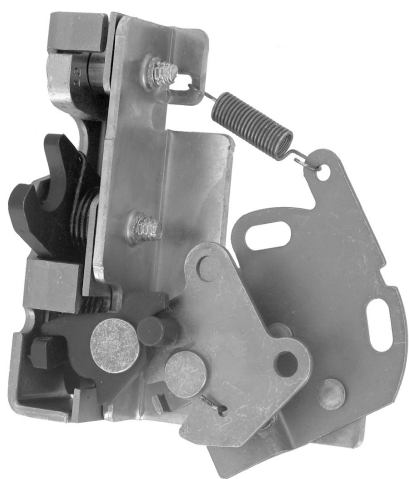

This latch and linkage system is intended for occupant or exit/entry doors for recreational vehicles including motor homes and travel trailers and specialty vehicles including ambulance, fire/rescue and off-highway vehicles (light duty) that require compliance to FMVSS 206 standards. The flexible design allows for internal or external door mounting and provides automotive logic function with remote activating handles.

#### **DESIGNED FOR:**

- Door weights up to 75 lbs (34 kg)
- Door seal pressures of 20-25 lbs (9-11 kg) recommended for best results (not to exceed 50 lbs [23 kg])
- Use with TriMark 070-0100 Striker Bolt



[www.trimarkcorp.com](http://www.trimarkcorp.com)

#### **TriMark Corporation**

500 Bailey Avenue  
P.O. Box 350  
New Hampton, Iowa 50659  
United States  
Tel: 641-394-3188  
Fax: 641-394-2392  
1-800-447-0343  
[www.trimarkcorp.com](http://www.trimarkcorp.com)



#### **TriMark Europe**

Cedar Court  
Walker Road  
Bardon Hill  
Coalville LE67 1TU  
United Kingdom  
Tel: +44(0)1530 512460  
Fax: +44(0)1530 512461  
[www.trimarkeu.com](http://www.trimarkeu.com)



**AVAILABLE:**

- Improved versions are available with increased mechanical advantage that reduce the release efforts at the exterior and interior handles. These versions retrofit with previous part numbers but may require connecting rod revisions, due to the increased length of the linkage and slightly revised rod connection points.
- Right or left hand configurations (left hand shown)
- Optional spacer plates may be required and is dependent upon the door frame thickness and the particular assembly used. Please consult TriMark engineering for the spacer plate distance required. Spacer plate is available to facilitate interior door mounting

**INSTALLATION:**

- Can be mounted inside or outside of door edge
- Three 1/4-20 UNC grade 5-type or better fasteners are recommended (not included)
- Tighten to the manufacturers' recommended torque value, however, do not exceed 120 in-lbs (13.3 N-m)

For more information visit  
[www.trimarkcorp.com](http://www.trimarkcorp.com)

**FINISH:**

- Zinc plated clear chromate steel components

**MATERIAL:**

- Internal latch components: heat treated, smooth edge stamped steel
- Springs: non-corrosive stainless steel
- Case halves: high strength steel

**INTERNAL LUBRICATION:**

- Oven-cured dry lubricant is applied on all critical moving parts

U.S. Patent No. 7,156,430 and 7,320,488

Individual part dimensions are for reference only. Refer to individual part drawings for complete dimensions, specifications, and installation procedures. Engineering assistance and application drawings are available.

Applications of this latch may fall within the requirements of FMVSS 206 and SAE J839 safety standards. These safety related requirements are dependent on door application, e.g. front and rear hinged doors, sliding doors, or hinged upward swinging doors. The entire door hardware system must be included in the design/analysis process: latch, handle, lock mechanism, cables/rods/linkages, fasteners, hinges, etc. This ensures compatibility of all components within the hardware system. If FMVSS 206 is a requirement, then all of the components within the door system must comply with strength, inertia and locking requirements as specified within the Standard. Note that this product complies with FMVSS 206 when tested with approved TriMark Striker Bolts in accordance with SAE J839 and that this product meets FMVSS 206 load requirements and may be used in FMVSS 206 applications pending TriMark application approval.

