

060-0475
Flush Baggage
Door e-LOCK



DESIGNED FOR:

- Baggage and compartment doors for recreational vehicles including motor homes and travel trailers
- Single and multi-point baggage and compartment door applications
- Compartment applications where it is desirable to have the ability to electrically lock the door

FEATURES/BENEFITS:

- Offers modernized styling
- Allows the use of power door lock actuation
- Large handle provides comfortable finger access and greater ease of operation (ergonomics)
- Single point zinc or plastic plunger or multi-point functionality works with TriMark rotary or plunger latches in doors 1.187" (30.1mm) and thicker
- Multi-point handle can be mounted in vertical or horizontal orientations and is able to actuate latches at the sides and also the top and bottom of the door
- Paddle can be locked before the door is closed (slam action)



www.trimarkcorp.com

TriMark Corporation

500 Bailey Avenue
P.O. Box 350
New Hampton, Iowa 50659
United States
Tel: 641-394-3188
Fax: 641-394-2392
1-800-447-0343
www.trimarkcorp.com

10002707 QM08 ISO 9001: 2008
10002707 TS09 ISO/TS 16949: 2009

TriMark Corporation

TriMark Europe

Cedar Court
Walker Road
Bardon Hill
Coalville LE67 1TU
United Kingdom
Tel: +44(0)1530 512460
Fax: +44(0)1530 512461
www.trimarkeu.com

427961 QM08 ISO 9001 : 2008
427961 UM ISO 14001 : 2004

TriMark Europe Ltd.

AVAILABLE:

- With or without plunger bolt for one or multi-point operation
- Single point version is available with a zinc or plastic plunger
- Handle can be keyed to match other TriMark RV door products with KeyOne™ Plus for a single-key system, keyed alike or provided non-locking
- Housing flange and internal gaskets provided for resistance to water and dirt infiltration
- Linkage rods available for your specific applications

INSTALLATION:

- Handle is easy to install with (3) #8-32 thread forming fasteners (supplied separately)
- Optional mounting bracket and rod allows the power actuator to mount to the handle for ease of installation
- Supplied with gasket already applied under recess in housing flange for simple, clean installation

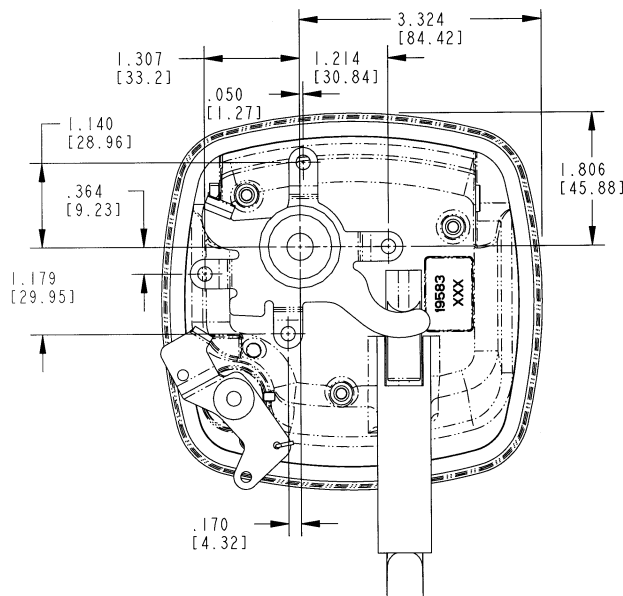

For more information visit
www.trimarkcorp.com

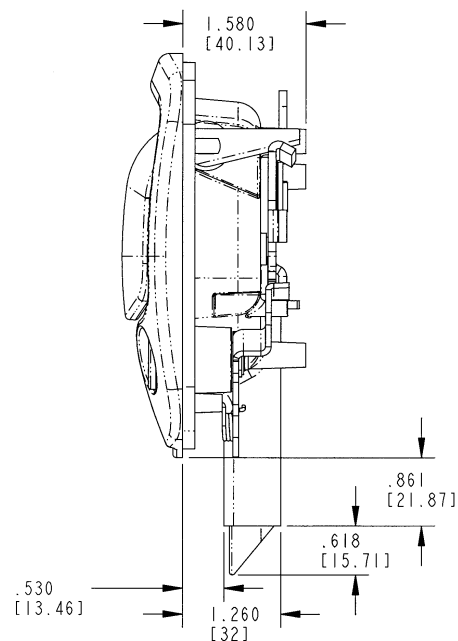
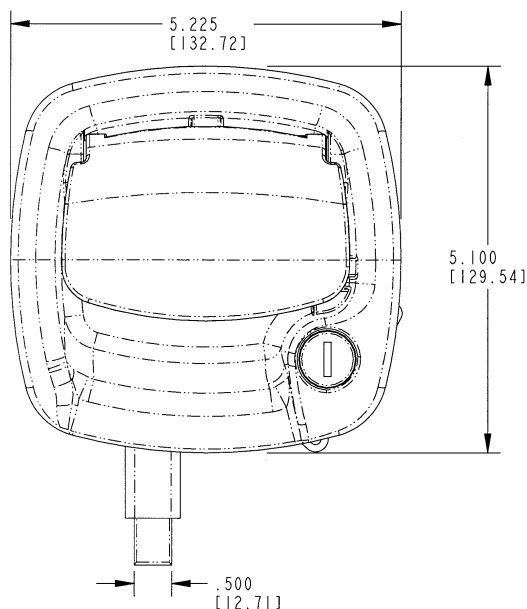

FINISH:

- Supplied painted in a low gloss black finish, the product can be easily painted over to match body colors
- Also available copper-nickel chrome plated

MATERIAL:

- Sturdy zinc die cast alloy housing, paddle and plunger
- All parts (axles, pivot arm, pivot plate, lock cam): cold rolled steel with zinc plate, clear chromate for corrosion resistance
- Engineering plastic used for plunger bolt drive end and plunger bolt (when specified) has lower coefficient of friction, reducing closing and operating efforts

System kits are available and include handles, latches, rods, brackets and power lock actuators to provide a comprehensive electro-mechanical access solution

The KeyOne™ Plus system allows the operation of multiple onboard locking hardware with a single key. Features include a reversible key for ease of operation and a larger body diameter for enhanced security. Please call for more information.



Individual part dimensions are for reference only. Refer to individual part drawings for complete dimensions, specifications, and installation procedures. Engineering assistance and application drawings are available.

U.S. Patent No. 7,232,162
Design Patent No. D519,823

