

010-0100
Release Lever



Designed as an inside release for use with TriMark's L-handles, this product offers a simple low cost handle for use on rotating drive bar applications



www.trimarkcorp.com

TriMark Corporation

500 Bailey Avenue
P.O. Box 350
New Hampton, Iowa 50659
United States
Tel: 641-394-3188
Fax: 641-394-2392
1-800-447-0343
www.trimarkcorp.com



TriMark Corporation

TriMark Europe

Cedar Court
Walker Road
Bardon Hill
Coalville LE67 1TU
United Kingdom
Tel: +44(0)1530 512460
Fax: +44(0)1530 512461
www.trimarkeu.com



TriMark Europe Ltd.

AVAILABLE:

- With 5/16" square hole at 90 degree or 45 degree orientation

MATERIAL:

- Die cast zinc alloy

FINISH:

- Mill -- unplated
- Copper-nickel-chrome plated
- Black powder coated

INSTALLATION:

- .156" (4.0mm) diameter roll pin (not included)
- 5/16" diameter set screw

Individual part dimensions are for reference only. Refer to individual part drawings for complete dimensions, specifications, and installation procedures. Engineering assistance and application drawings are available

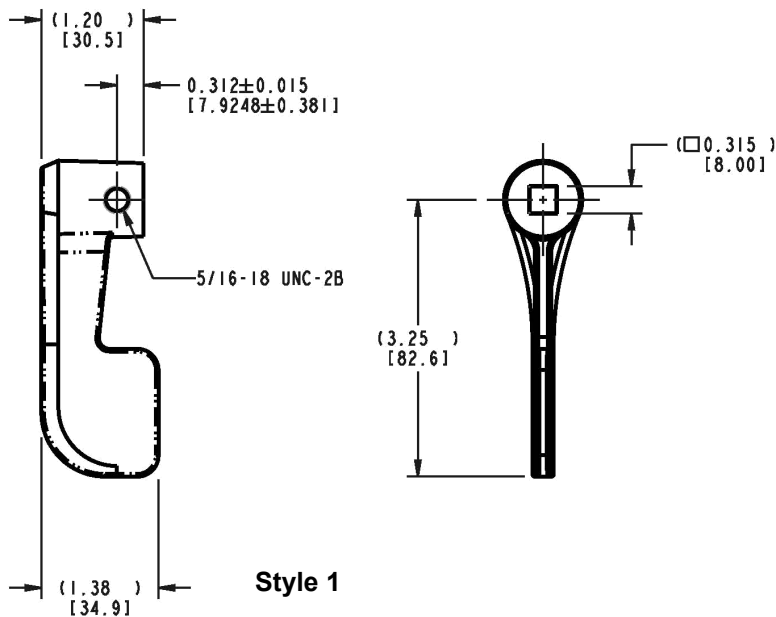

For more information visit
www.trimarkcorp.com

